

ERGON[®] S40

LIVING

technical construction and installation manual

swinging sliding door with connecting rod in the door leaf

技术说明及安装手册

双向魔术门（连接杆位于门扇内）

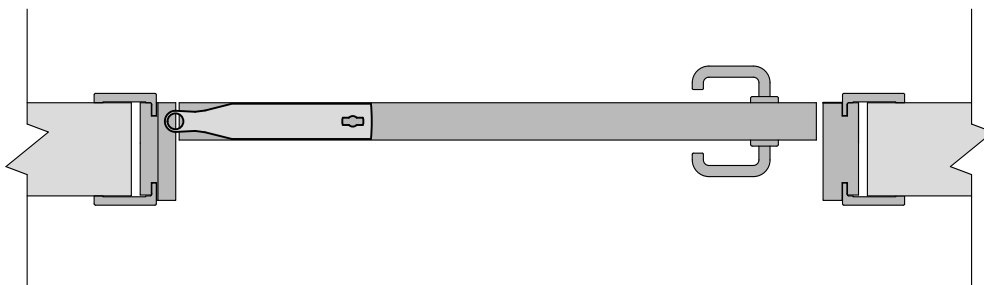

INDEX

Exploded view of the hardware五金爆炸图	page 3
Introduction介绍	page 4
Frame specification门框说明	page 5
Single door horizontal dimension diagram单门水平剖面图	page 6
子母门水平剖面图 (一侧装Ergon)	page 7
双开门水平剖面图 (两侧装Ergon)	page 8
Vertical dimensional diagram垂直尺寸图	page 9
Managing wall thickness墙体厚度管理	page 10
Working door leaf specification门扇加工孔位图	page 11
Exploded view of the frame (jamb with doorpost)门套爆炸分解图(企口门套)	page 12
Details for vertical frame (jamb with doorpost)垂直门套加工图(企口门套)	page 13-14
Exploded view of the frame (straight frame)门套爆炸分解图(平口门套)	page 15
Details for vertical frame (straight frame)垂直门套加工图(平口门套)	page 16
Details for the upper crossbeam横向门套加工图	page 17
Track adjustment to the width not standard非标宽度的轨道裁切方法	page 18
Rod kit shortnable垂直连接杆的裁切	page 19
双扇Ergon门的轨道工具套件	page 20-21
Magnetic strker plate for "Push&Go EVO"磁力插销扣板的安装板	page 22
Assembling the hardware in the door leaf门扇五金的组装	page 23
Assembly frame to track轨道与门套的组装	page 24
Complete door jamb installation门套的安装	page 25
Door leaf installation门扇的安装	page 26
Adjusting door leaf and door jamb门扇门套的调节	page 27
"Soft Opening" installation (optional)缓冲器的安装(可选)	page 28-29
Frames and track cover installation门套和轨道装饰盖的安装	page 30

EXPLODED VIEW OF THE HARDWARE 爆炸图

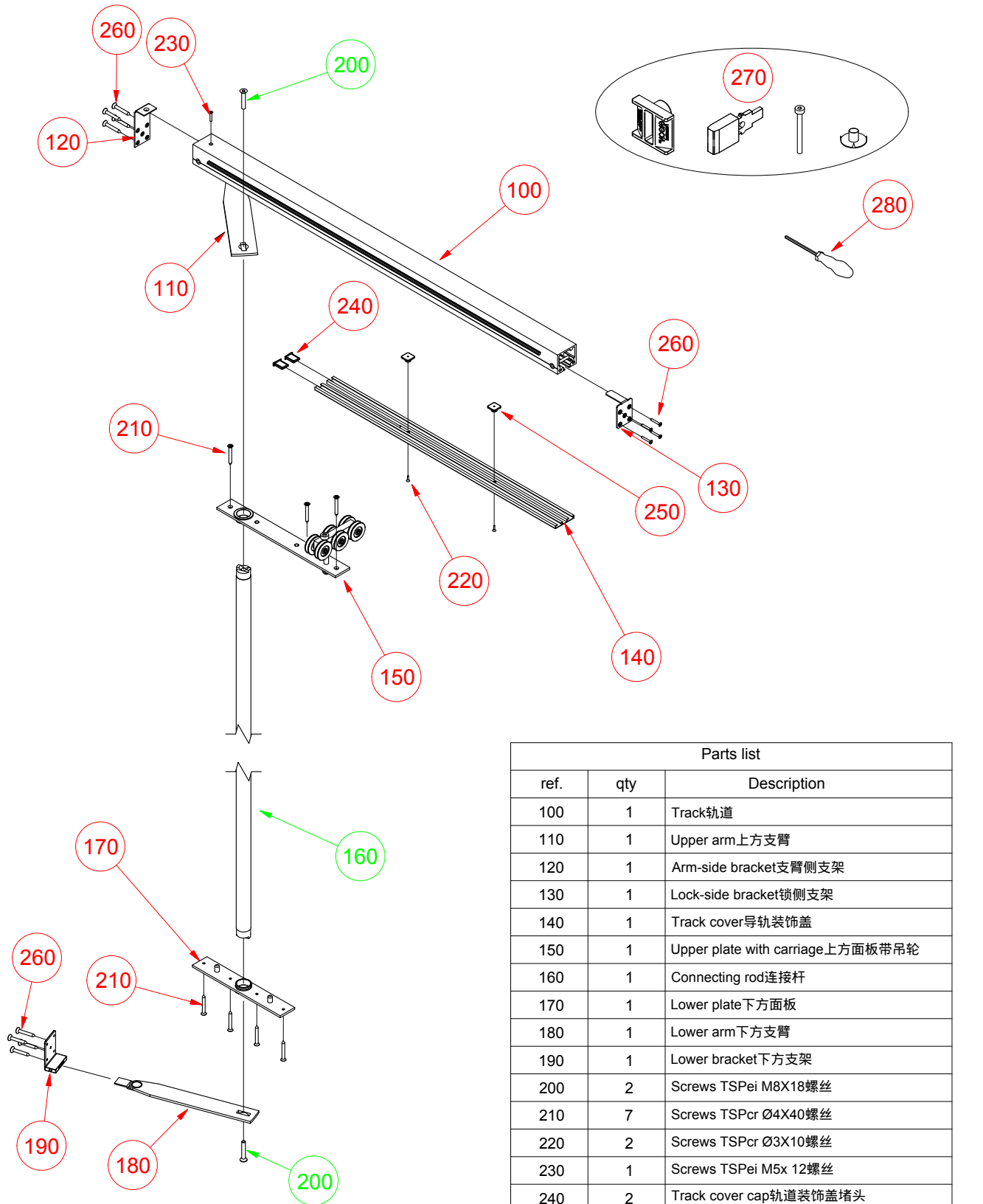

Parts list		
ref.	qty	Description
100	1	Track轨道
110	1	Upper arm上方支臂
120	1	Arm-side bracket支臂侧支架
130	1	Lock-side bracket锁侧支架
140	1	Track cover导轨装饰盖
150	1	Upper plate with carriage上方面板带吊轮
160	1	Connecting rod连接杆
170	1	Lower plate下方面板
180	1	Lower arm下方支臂
190	1	Lower bracket下方支架
200	2	Screws TSPei M8X18螺丝
210	7	Screws TSPcr Ø4X40螺丝
220	2	Screws TSPcr Ø3X10螺丝
230	1	Screws TSPei M5x 12螺丝
240	2	Track cover cap轨道装饰盖堵头
250	2	Track cover installation insert轨道装饰盖安装孔盖
260	12	Screws TSPcr Ø3,5x30螺丝
270	1	Mediana evolution lock set双向锁舌
280	1	Hexagonal screwdriver mm 2,5内六角扳手

■ Component present in the track kit
红色在轨道套装内

■ Component present in the rod kit
绿色在连接杆套装内

INTRODUCTION

ERGON LIVING S40 五金只能应用于住宅房间内部的空心房门，厚度不低于40mm，重量不超过70kg。

为了确保可靠性和使用便捷，所采用的部件均来自于已经过成千上万次测试的ERGON系列。ERGON系统已经在CATAS研发实验室，根据欧洲标准EN1191/00的要求，通过了10万次的开关使用寿命测试。由于连接杆位于门扇内而非门套内，因此ERGON LIVING S40可以采用标准门套，只需要根据手册内的说明，简单改动即可。

ERGON LIVING S40的标准表面处理为银色和黑色，并且为了将门扇在运动过程中的阻碍降低到最小，共有三种支臂可供选择：

- "Base" “标准版”适用于 LFM (门洞宽度)从800至1100 mm;
- "Small" “小号”适用于 LFM (门洞宽度)从610至800 mm;
- "Large" “大号”适用于 LFM (门洞宽度)从1100至1450mm.

根据特定要求，采用ERGON LIVING S40五金，房门可以根据不同的墙体厚度，安装在任意位置。但是为了简化说明，手册里用特定术语描述了两种极限位置。

1) "**centered door**" “中间门扇” 门扇位于墙体中间; 这种方案的优点是房门的制作与安装无关。因为门扇位于墙体中间且双向开启，因此开启方向可以在安装时再确定，门扇的制作不会因为开启方向做任何修改。 t

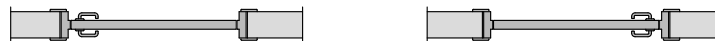

2) "**oriented door**" “偏心门” 是门扇位于墙体的其中一侧；这种情况下，房门的制作必须考虑到其安装开启方向。

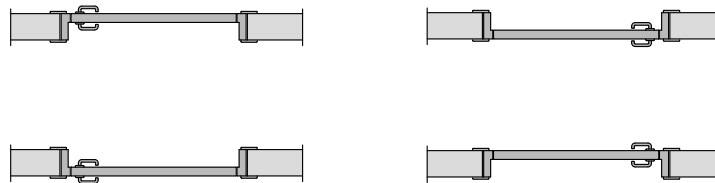

根据passage widths通过宽度的不同，ERGON LIVING S40在不同的支臂类型中(*Base, Small, Large*标准版，小号，大号)又细分了不同的特定尺寸. 然后，使用了某一特定尺寸的五金之后，也可以通过裁切轨道以及轨道盖板的方式（见18页），来获取两个特定尺寸之间的任意尺寸.

至于actual passage height实际通过高度，可以采用固定高度的连接杆，如果不是常规高度，可以订货一个特殊可裁切连接杆，通过裁切连接杆（见19页）来获取非常规高度。

FRAME SPECIFICATION 门框说明

ERGON LIVING S40 可以使用两种门框结构: **jamb with doorpost** and **straight jamb**.

JAMB WITH DOORPOST 带门柱的门框

- 1) Furthermore it allows a production standard, as it makes it possible to manage both small and large wall thickness (up to 74 cm with door positioned in the centre of the wall thickness).
Moreover, the jamb can be placed indistinctly on the right or left side of the doorpost; in this way, it can be used for internal, external or central flush doors.
The adjacent doorpost, even if simple, is an extra element that must be constructed.
- 2) A suitably modified Mediana Evolution lock, using simple pressure to substitute the standard spring lock with the **ERGON** lock (presente su ogni confezione di ferramenta), allows the door to close similarly to a door with a rabbet. A magnetic lock can be used too.

STRAIGHT JAMB 平框

- 1) 可以使用平框，只是为了护墙形成一个门洞，前期没有规划装门扇。
- 2) Makes it necessary to use a magnetic lock which is functional only if the door is not more than 3 mm from the frame.
The door jamb near the lock is visually appealing in that no element of the lock or its release is visible.

* The movement of the door leads to having limits in the thickness of the walls which may vary depending on the type of frame used or on the type of bracket used (BASE, SMALL, LARGE); on page 10 there are some solutions to manage these limits in the best way possible.

RABBET DOOR WITH ONE-WAY OPENING

In some rooms of the house, it may be appropriate to use doors with stops, with the **ERGON** system; this is possible by simply creating stops in the vertical sides of the door using the same kit.
In this way there's not more the double-way opening, but there is a better acoustic isolation inside the room by using a seal for the tightness.
With the **ERGON** system with one-way opening, any type of lock can be used.
Fig. 2 below shows a constructive example of an **ERGON** door with stop; to create the stops both on the door and on the frame, they must be specular (fig. 3) and it is necessary to pay attention to value "X" which must be added to value "A", indicated on page 11 of this manual, to keep the panel connection rod insertion point in the exact position.

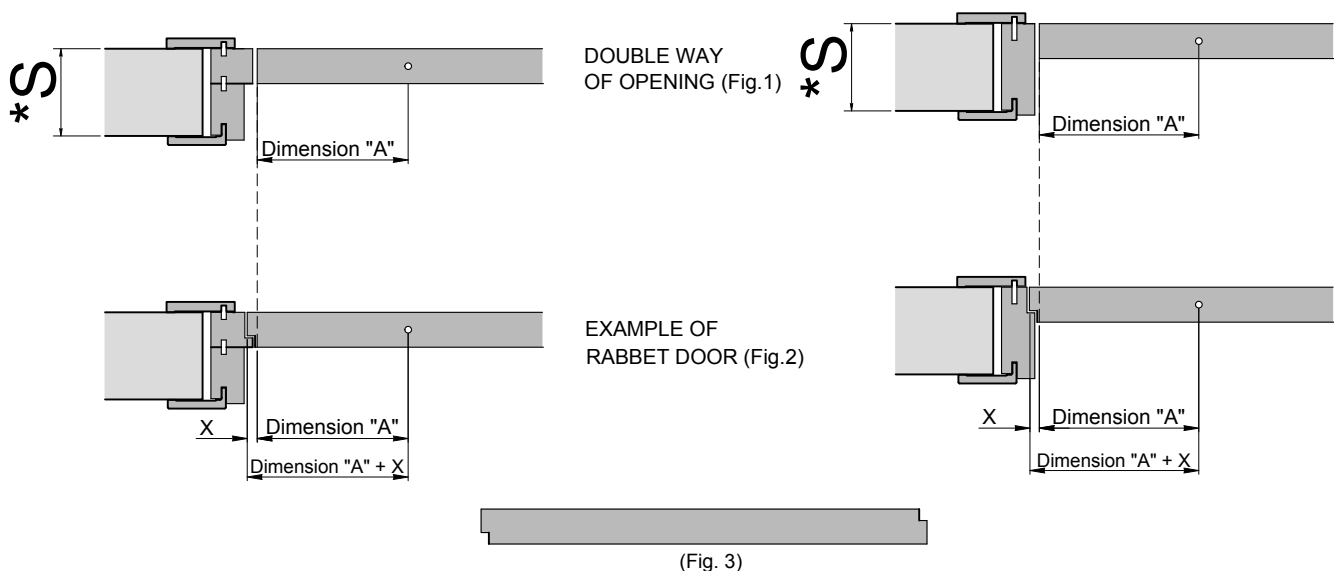

SINGLE DOOR HORIZONTAL DIMENSION DIAGRAM单开门俯视图

(示范尺寸)

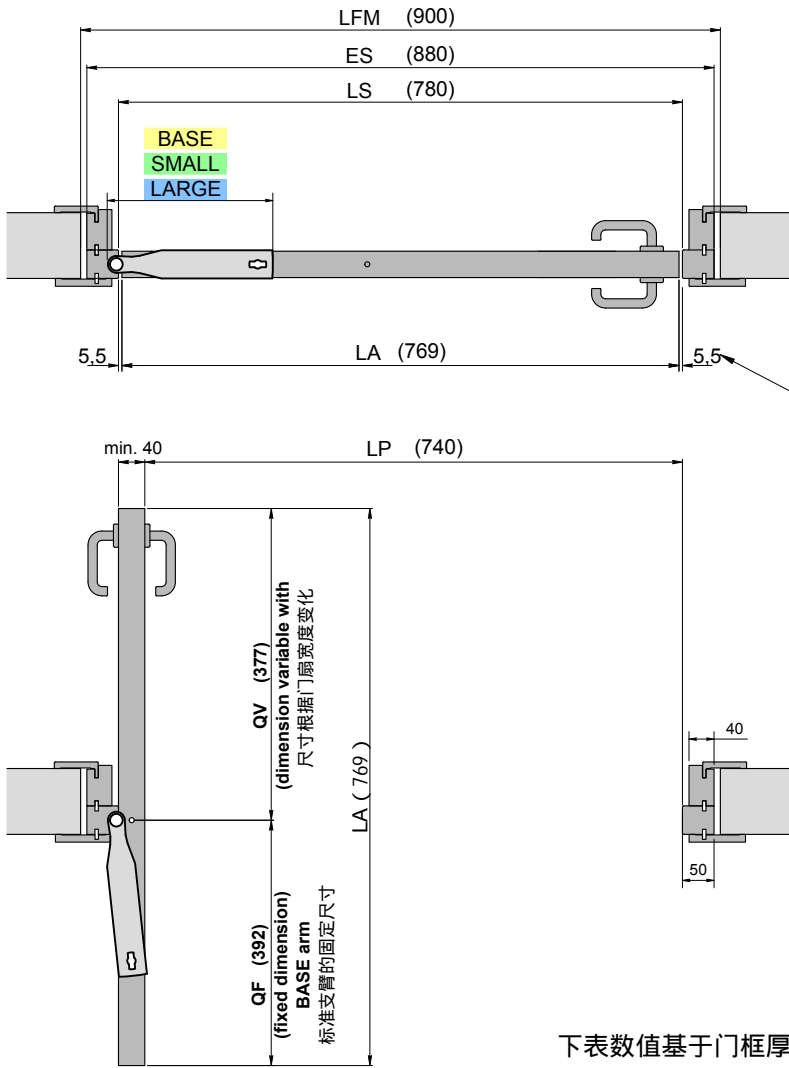

门扇可以安装于墙体的中间

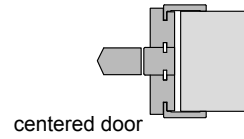

更多墙体厚度的信息见第10页

If a magnetic lock is used, it is recommended to reduce the gap to 3 mm on this side only.
如果使用磁力锁体，建议此侧的缝隙缩减为3mm

ATTENTION注意:
如果门扇很窄，要小心把手会和门框冲突。注意把手的尺寸，门扇和墙体的厚度。

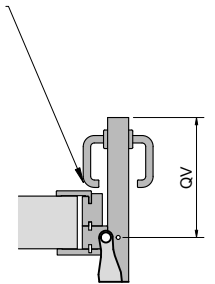

下表数值基于门框厚度50mm以及门扇厚度45mm; 如果使用40mm厚度的平框，则LP, LA, LS 和QV的数值要各增加20 mm。

	LARGE	BASE	SMALL	WIDTH DIMENSION宽度尺寸					
				LFM 墙体洞口尺寸	LP 净通过尺寸	LA 门扇宽度	QF 固定尺寸		QV 可变尺寸
			●	610	450	479	295		174
			●	650	490	519	295		224
带“缓冲开启”功能，小号支臂的最小尺寸		●	●	700	540	569	392	295	177 274
带“缓冲开启”功能，标准支臂的最小尺寸		●	●	750	590	619	392	295	227 324
		●	●	800	640	669	392	295	277 374
		●	●	850	690	719	392		327
		●	●	900	740	769	392		377
		●	●	950	790	819	392		427
		●	●	1000	840	869	392		477
		●	●	1050	890	919	392		527
带“缓冲开启”功能，大号支臂的最小尺寸	●	●	●	1100	940	969	620	392	349 577
	●			1150	990	1019	620		399
	●			1200	1040	1069	620		449
	●			1250	1090	1119	620		499
	●			1300	1140	1169	620		549
	●			1350	1190	1219	620		599
	●			1400	1240	1269	620		649
	●			1450	1290	1319	620		699

LEGEND

- LFM** = WALL HOLE WIDTH墙体洞口尺寸
- LP** = PASSAGE DIMENSION净通过尺寸 (LFM - 160)
- LA** = DOOR LEAF WIDTH 门扇宽度 (LFM - 131)
- LS** = DOOR JAMB OPENING门框内净空 (LFM - 120)
- ES** = OUTER JAMB门框外宽度 (LFM - 20)
- QF** = 支臂侧的固定尺寸
- QV** = 把手侧的可变尺寸

- = Available standard dimensions标准尺寸
- = Several examples of dimensions that can be obtained by shortening the track. Intermediate dimensions are also possible.需要裁切轨道可实现的尺寸。

For other custom dimensions, contact Celegon in regards to feasibility.

DOUBLE DOOR HORIZONTAL DIMENSIONAL DIAGRAM (ERGON DOOR LEAF AND RABBET DOOR)
子母门俯视图 (单侧安装ERGON)

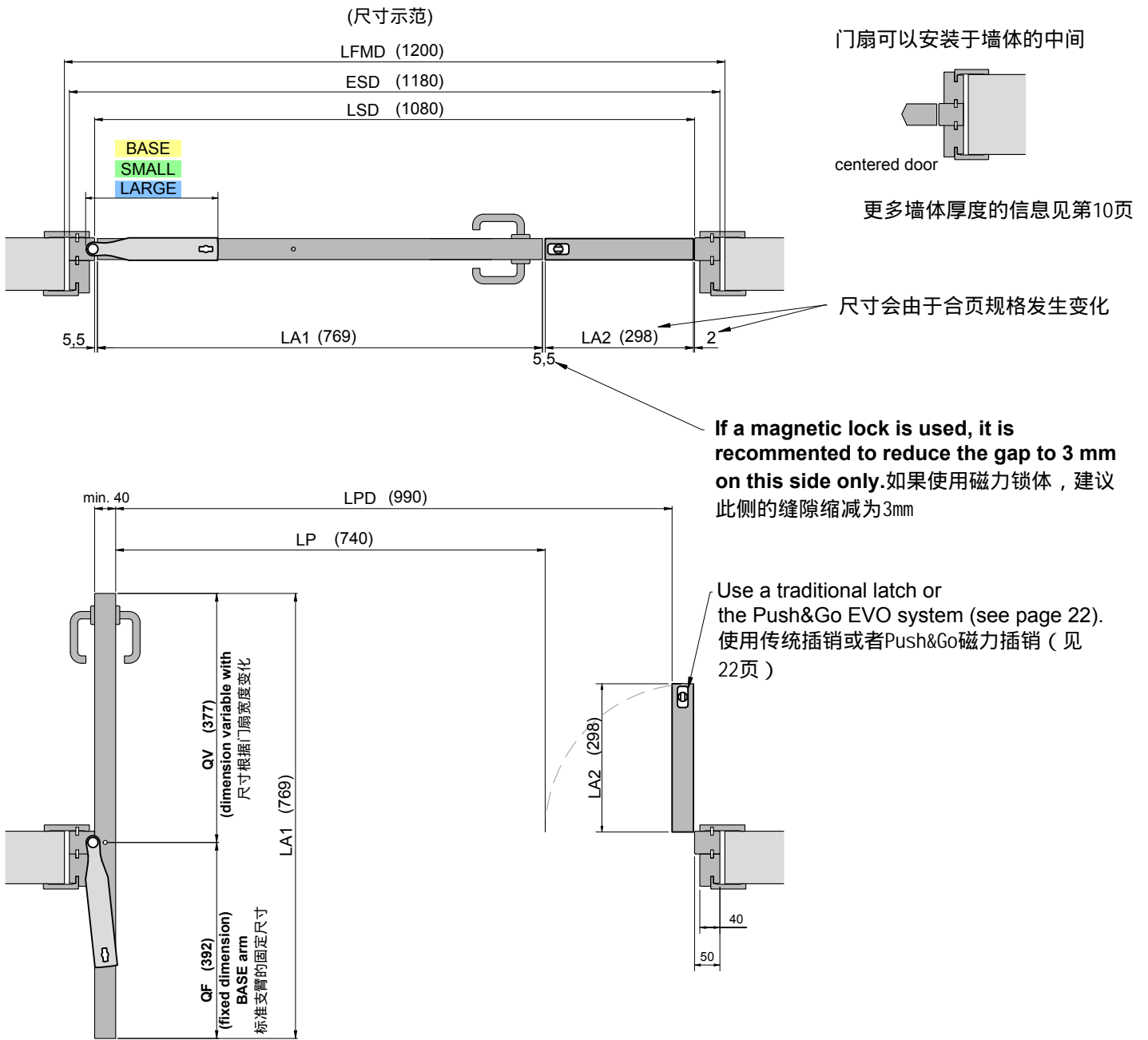

表格数值基于门框厚度50mm以及门扇厚度45mm如果使用40mm厚度的平框, 则LP和LS的数值增加20 mm, LA和QV的数值增加10 mm.

订购五金时候, 墙体洞口尺寸(LFMD) 以及支臂类型必须提供。

A custom track kit will be supplied based on the dimensions provided.

LEGEND

- LFMD** = WALL HOLE WIDTH 墙体洞口尺寸
- LPD** = PASSAGE DIMENSION 净通过尺寸 (LFMD - 210)
- LA1** = DOOR LEAF WIDTH 门扇宽度 (见第5页的表格)
- LA2** = DOOR LEAF WIDTH 门扇宽度 (LFMD - LA1 - 133 因LA1和铰链的规格变化而异)
- LSD** = DOOR JAMB OPENING 门框净空 (LFMD - 120)
- ESD** = OUTER JAMB 门框外口宽度 (LFMD - 20)
- QF** = FIXED DIMENSION ENCUMBRANCE ARM-SIDE 支臂侧的固定尺寸 (见第6页表格, 根据支臂类型不同而变化)
- QV** = HANDLE SIDE VARIABLE DIMENSION 把手侧的可变尺寸 (见第6页表格, 根据支臂类型和 LA1 不同而变化)

DOUBLE DOOR HORIZONTAL DIMENSIONAL DIAGRAM (TWO ERGON DOOR LEAVES)
双开门俯视图 (两侧安装ERGON)

(示范尺寸)

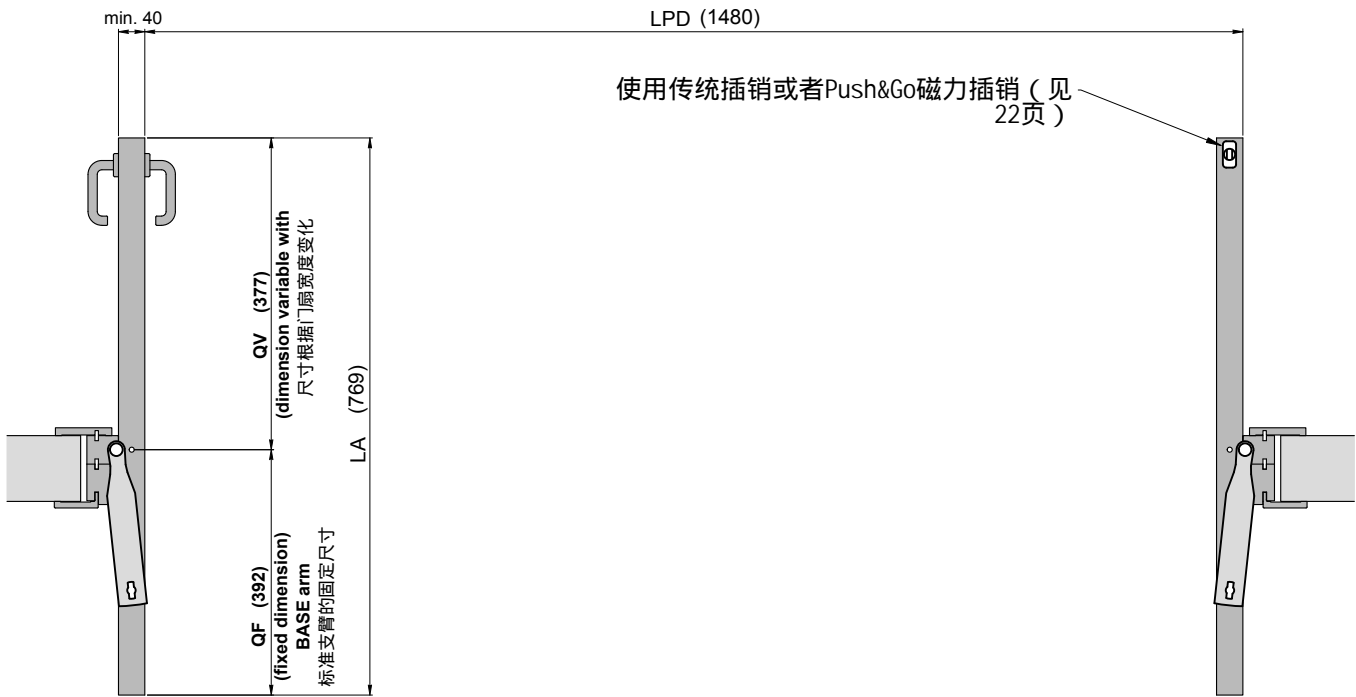
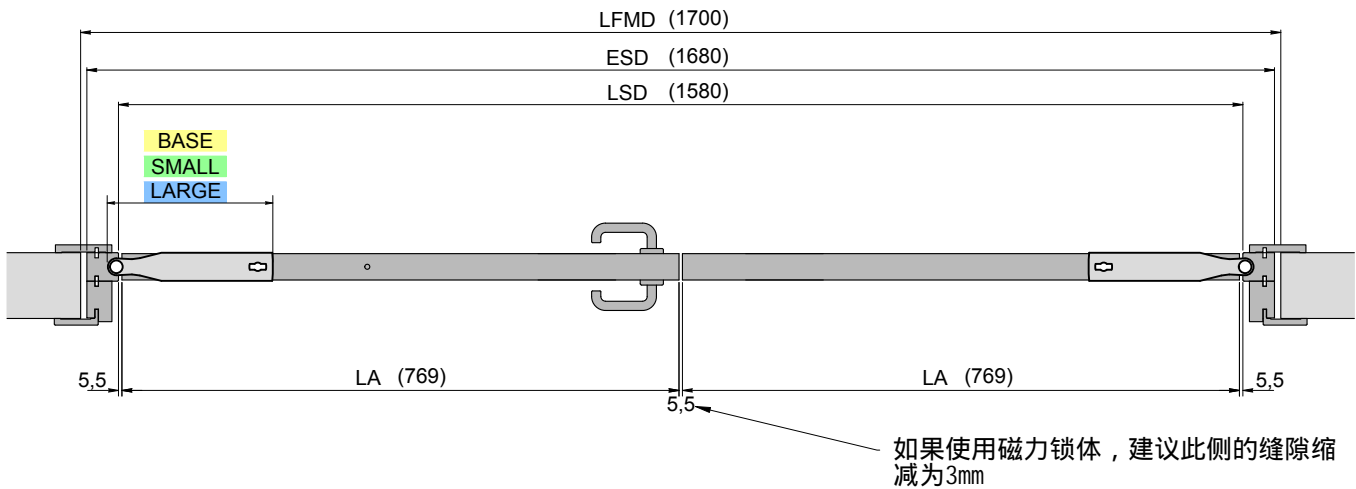

表格数值基于门框厚度50mm以及门扇厚度45mm如果使用40mm厚度的平框, 则LP和LS的数值增加20mm, LA和QV的数值增加10 mm.

这种情况下, 可以使用轨道连接器将两个单门轨道连接在一起。详见20-21-22页。

LEGEND

- LFMD** = WALL HOLE DIMENSION 墙体门洞尺寸
- LPD** = PASSAGE DIMENSION 净通过尺寸 (LFMD - 210)
- LA** = DOOR LEAF WIDTH 门扇尺寸 ($\frac{LFMD - 162}{2}$)
- LSD** = DOOR JAMB OPENING 门框净空 (LFMD - 120)
- ESD** = OUTER JAMB 门框外宽度 (LFMD - 20)
- QF** = FIXED DIMENSION ENCUMBRANCE ARM-SIDE 支臂侧的固定尺寸
- QV** = VARIABLE DIMENSION ENCUMBRANCE HANDLE-SIDE 把手侧的可变尺寸

门扇可以安装于墙体的中间

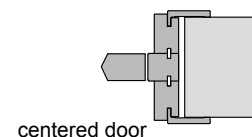

更多墙体厚度的信息见第10页

VERTICAL DIMENSIONAL DIAGRAM 正视图

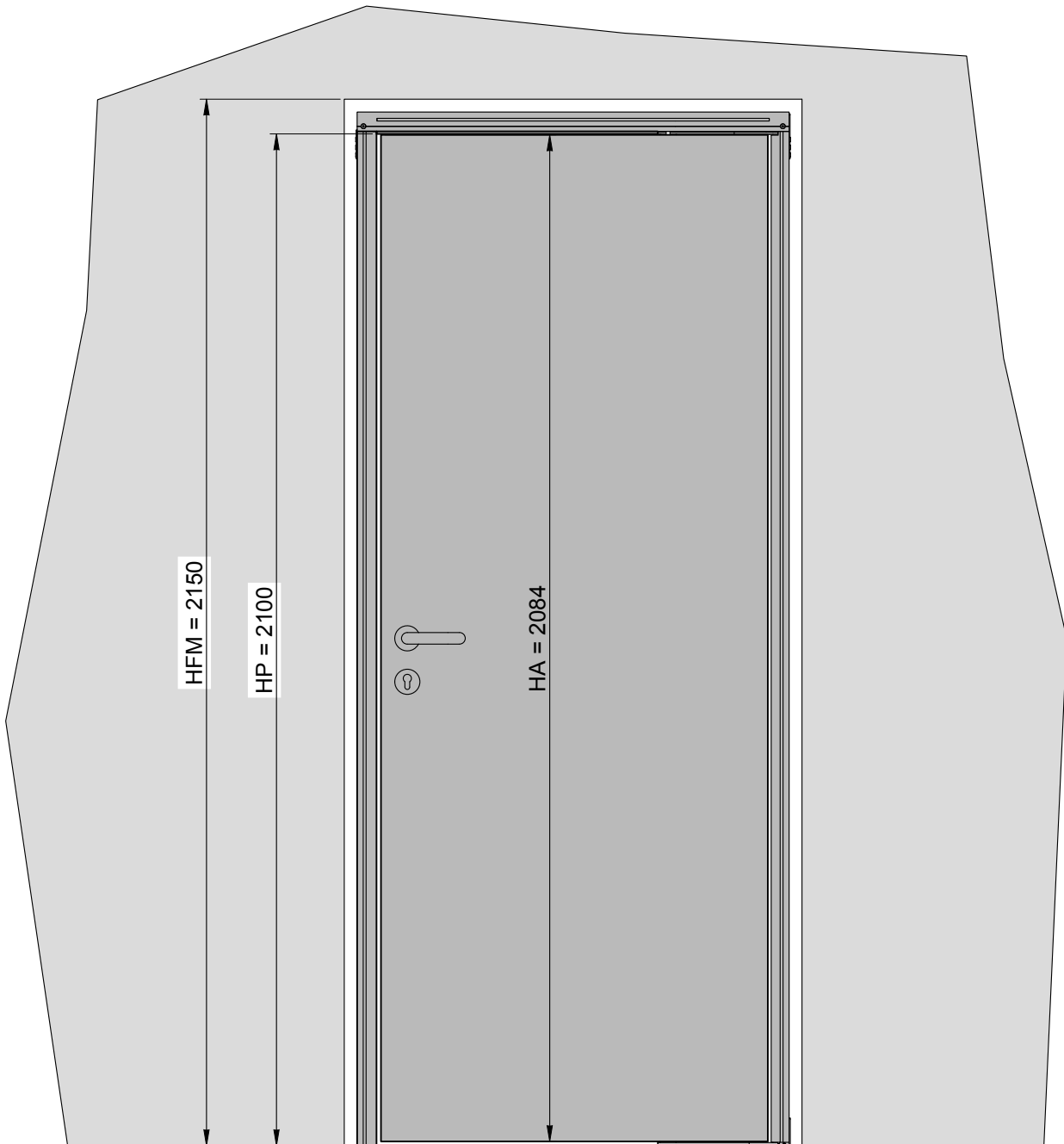

VERTICAL DIMENSIONAL			
HFM 门洞高度	HP 净通过高度	HA 门扇高度	
* 1950	1900	1884	HP = (HFM - 50) HA = (HFM - 66)
* 2000	1950	1934	
* 2050	2000	1984	
* 2100	2050	2034	
* 2150	2100	2084	
* 2200	2150	2134	
* 2250	2200	2184	
* 标准尺寸。 可采购可裁切的连接杆适用于其他高度。			

MANAGING WALL THICKNESS

特殊的运动轨迹使得门扇在开启时产生后退，意味着需要特别注意墙体厚度，防止门扇碰撞到门框表面（见下图）

下图尺寸基于门扇厚度为 45 mm.

带门柱的门框

- 厚度最大 **max. 180 mm** 小号 **SMALL** 支臂
- 厚度最大 **max. 260 mm** 常规 **BASE** 支臂
- 厚度最大 **max. 390 mm** 大号 **LARGE** 支臂

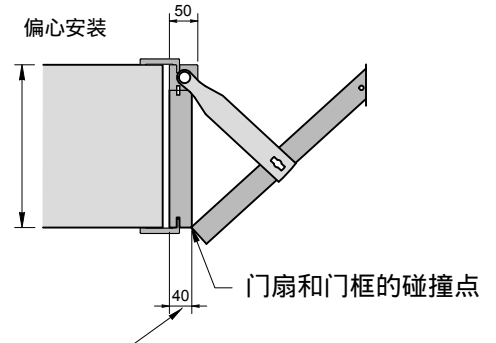

为了增加墙体厚度, 可以使门框厚度小于 <40 mm.

通过压缩门框厚度小于40 mm, 墙体厚度可以增加30mm, 每压缩2mm门框厚度 (例如门框厚度38mm = **BASE** arm 墙体厚度 290 mm).

平框

- 厚度最大 **max. 60 mm** for **SMALL** arm
- 厚度最大 **max. 110 mm** for **BASE** arm
- 厚度最大 **max. 135 mm** for **LARGE** arm

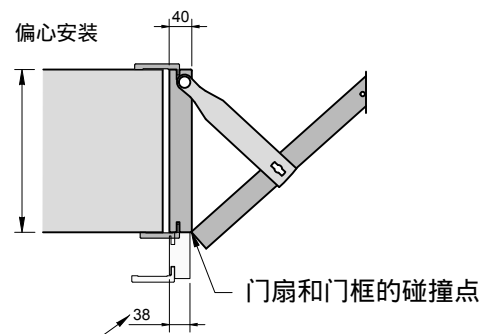

To increase the thickness of the wall, an element can be added to the frame with a smaller thickness than the frame itself (e.g. frame thickness 40 mm add 38 mm element).

In this way it is possible to increase the thickness of the wall by about 30 mm every 2 mm (e.g. adding a 38 mm element = wall thickness **BASE** bracket 140 mm).

By positioning the door at the centre of the jamb, the maximum wall thickness can be increased.

JAMB WITH DOORPOST

- thickness **max. 320 mm** for **SMALL** arm
- thickness **max. 480 mm** for **BASE** arm
- thickness **max. 740 mm** for **LARGE** arm

STRAIGHT FRAME

- thickness **max. 80 mm** for **SMALL** arm
- thickness **max. 150 mm** for **BASE** arm
- thickness **max. 230 mm** for **LARGE** arm

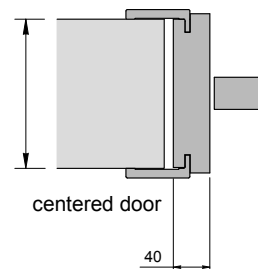
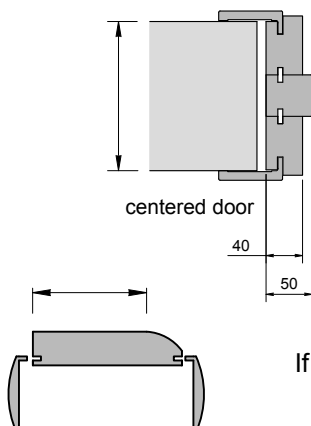

If rounded jambs are used, the above thickness wall dimension must be calculated only on the plane surface and not on the rounded side.

WORKING DOOR LEAF SPECIFICATION 门扇制作说明

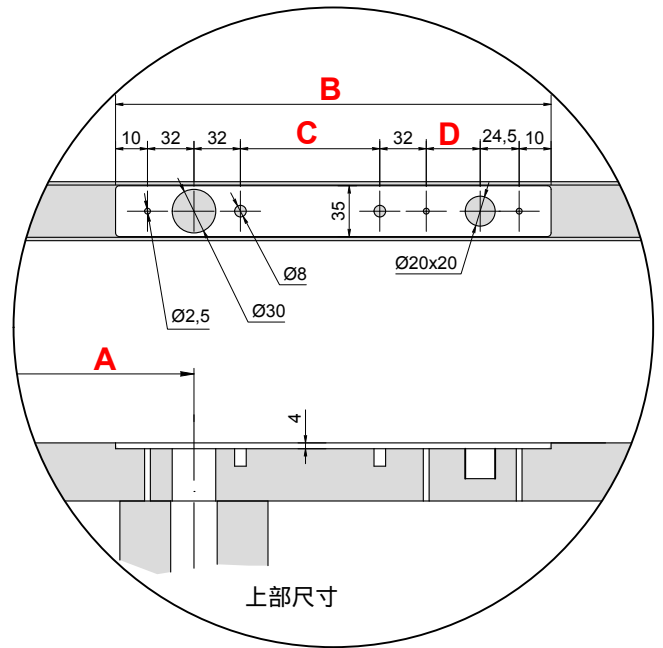
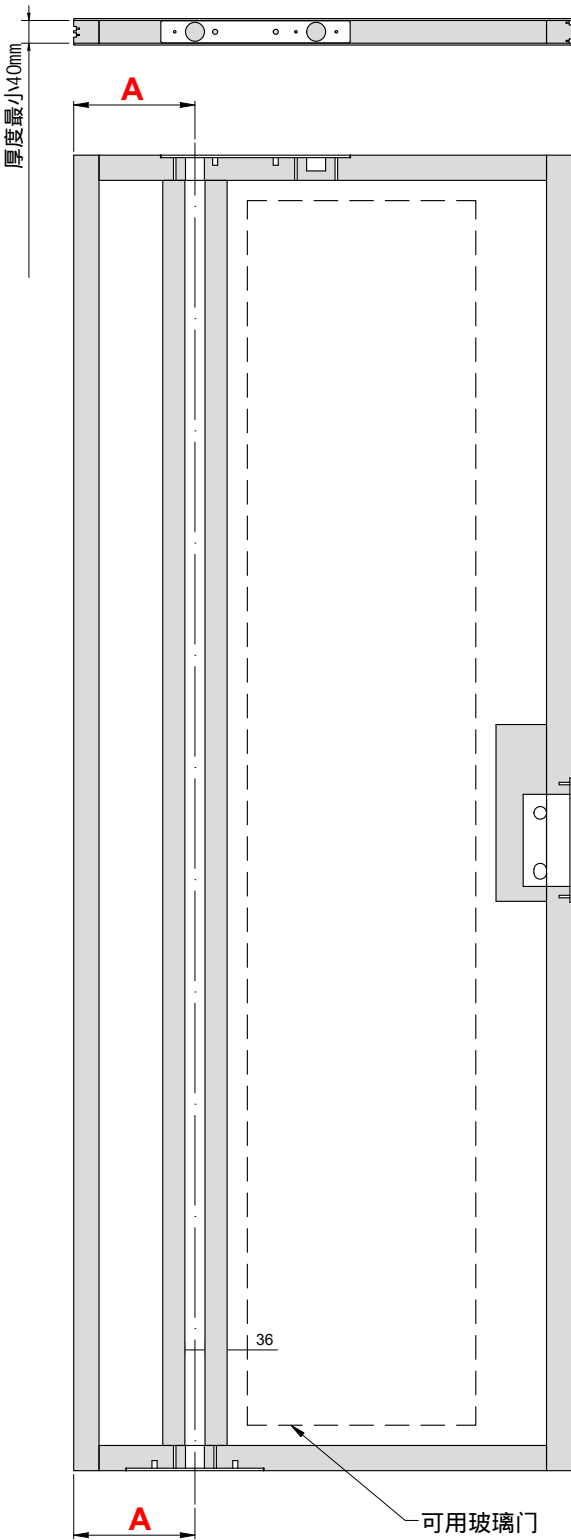

可变尺寸基于支臂类型

	A	B	C	D
BASE arm	192	276	96	39,5
SMALL arm	144	227,3	47,3	39,5
LARGE arm	306	390	224	25,5

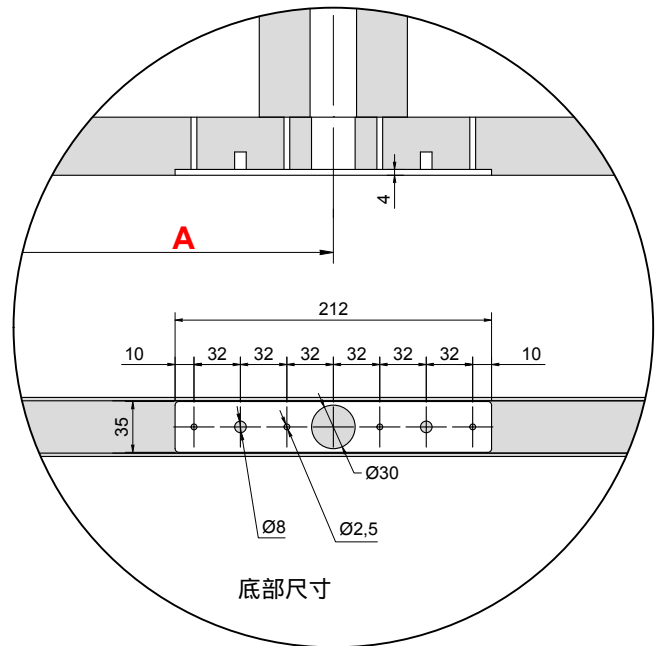

It is recommended to use a lock with facing no larger than 18 mm.

门套爆炸分解图 (企口门套)

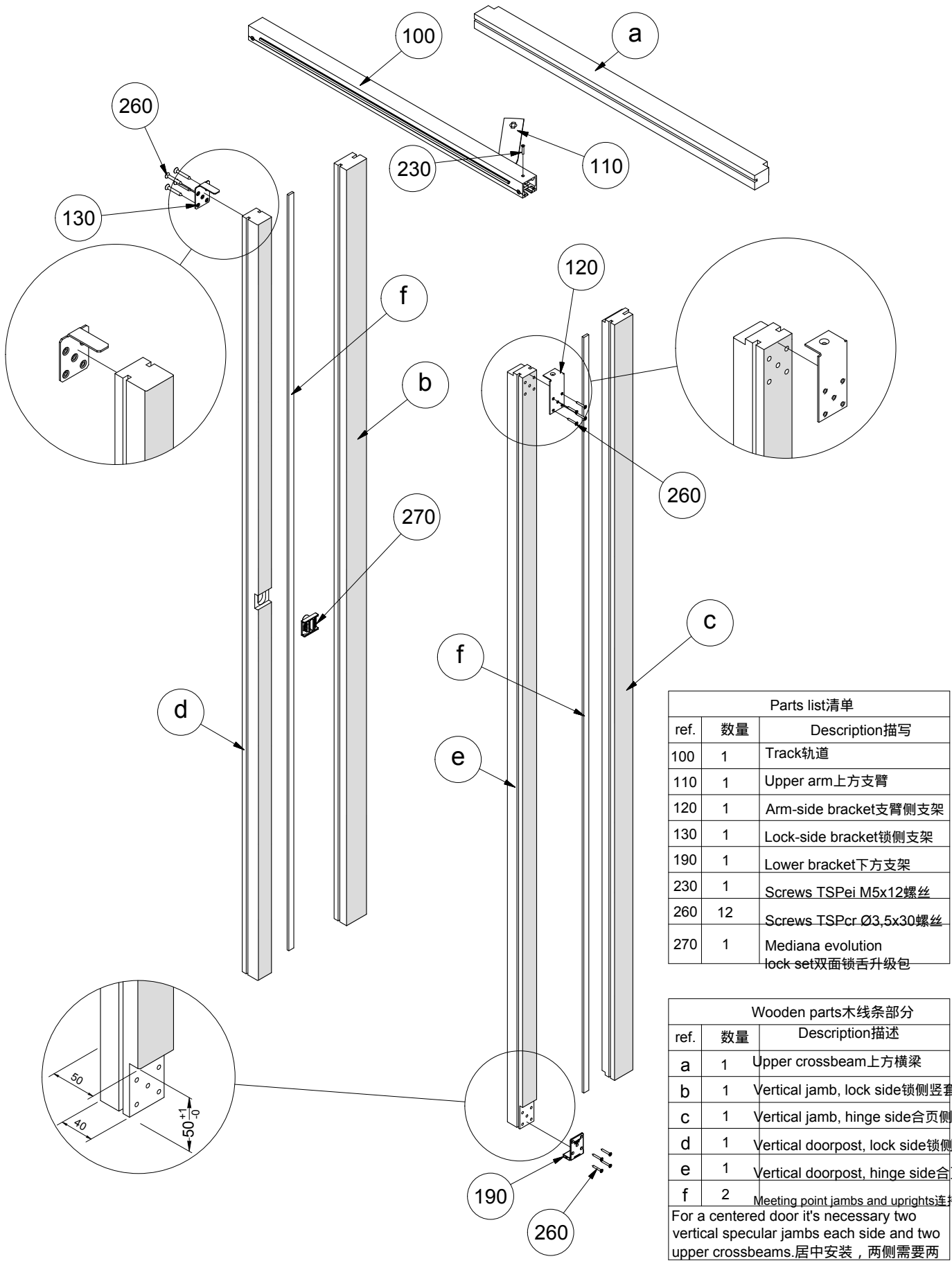

Parts list清单		
ref.	数量	Description描述
100	1	Track轨道
110	1	Upper arm上方支臂
120	1	Arm-side bracket支臂侧支架
130	1	Lock-side bracket锁侧支架
190	1	Lower bracket下方支架
230	1	Screws TSPei M5x12螺丝
260	12	Screws TSPcr Ø3,5x30螺丝
270	1	Mediana evolution lock set双面锁舌升级包

Wooden parts木线条部分		
ref.	数量	Description描述
a	1	Upper crossbeam上方横梁
b	1	Vertical jamb, lock side锁侧竖套板
c	1	Vertical jamb, hinge side合页侧竖套板
d	1	Vertical doorpost, lock side锁侧门框
e	1	Vertical doorpost, hinge side合页侧门框
f	2	Meeting point jambs and uprights连接条

For a centered door it's necessary two vertical specular jambs each side and two upper crossbeams.居中安装, 两侧需要两个对称的竖套板和上横梁

垂直门套板加工图 (企口门套)

DOORPOST ARM SIDE 支臂侧门框

JAMB ARM SIDE 支臂侧套板

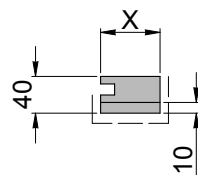
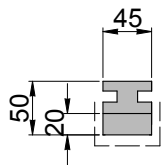
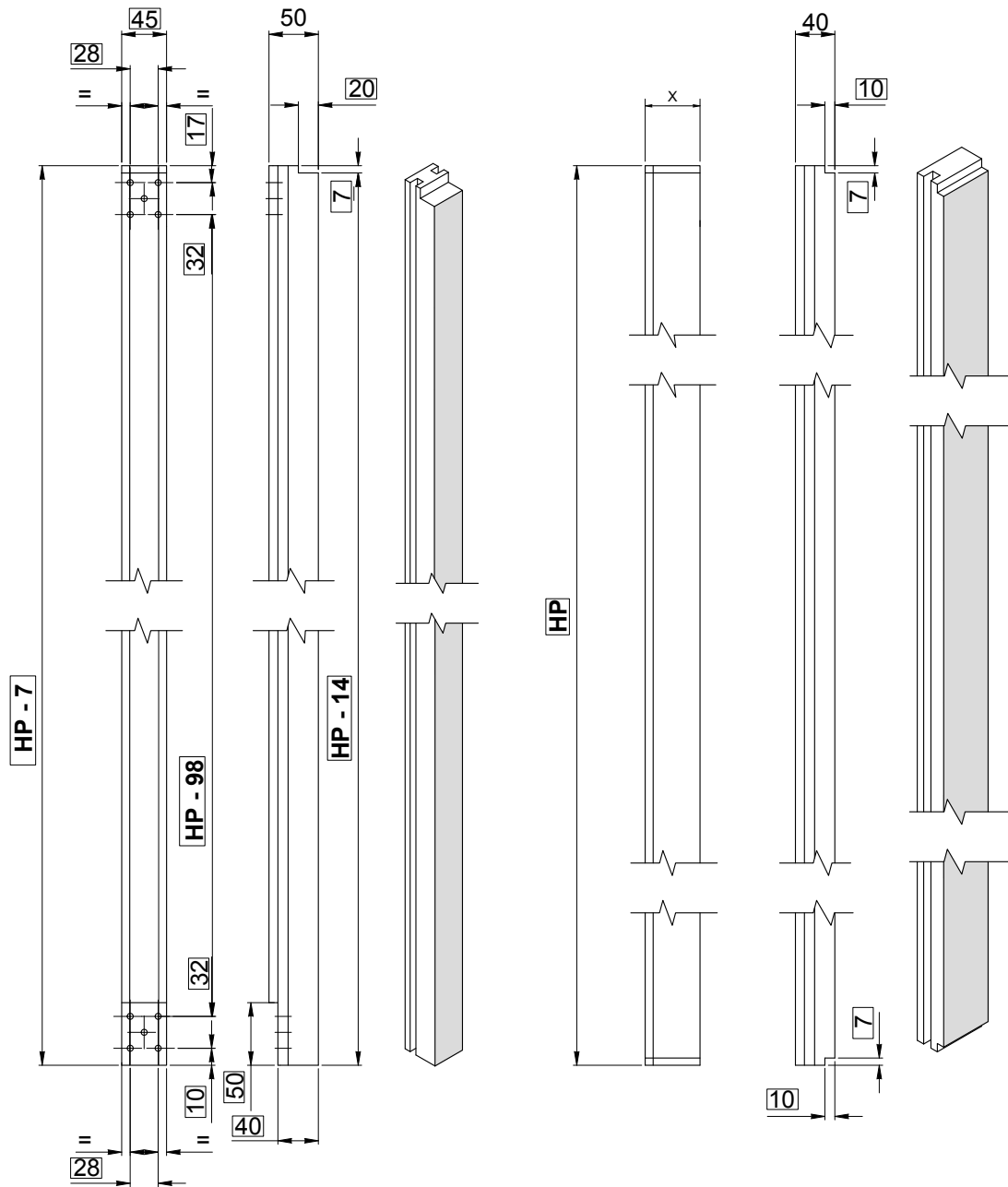

DIMENSION THAT BE ACCURATE
需精确的尺寸

X = WALL THICKNESS - 45
X=墙体厚度-45

HP = PASSAGE DIMENSION
HP=通过尺寸

--- VISIBLE SIDE
可见的边

偏心安装

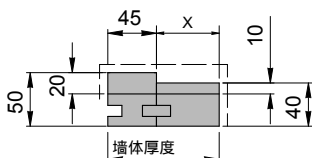

居中安装

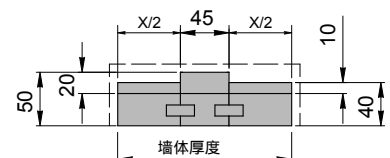

FOR CENTERED DOOR IS NECESSARY TWO SPECULAR JAMB
居中安装的门需要两个对称的套板

DETAILS FOR VERTICAL FRAME (JAMB WITH DOORPOST)垂直门框加工图 (企口门套)

DOORPOST LOCK SIDE锁侧门框

JAMB LOCK SIDE锁侧门套板

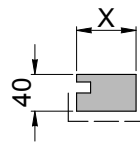
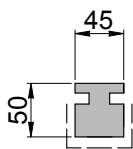
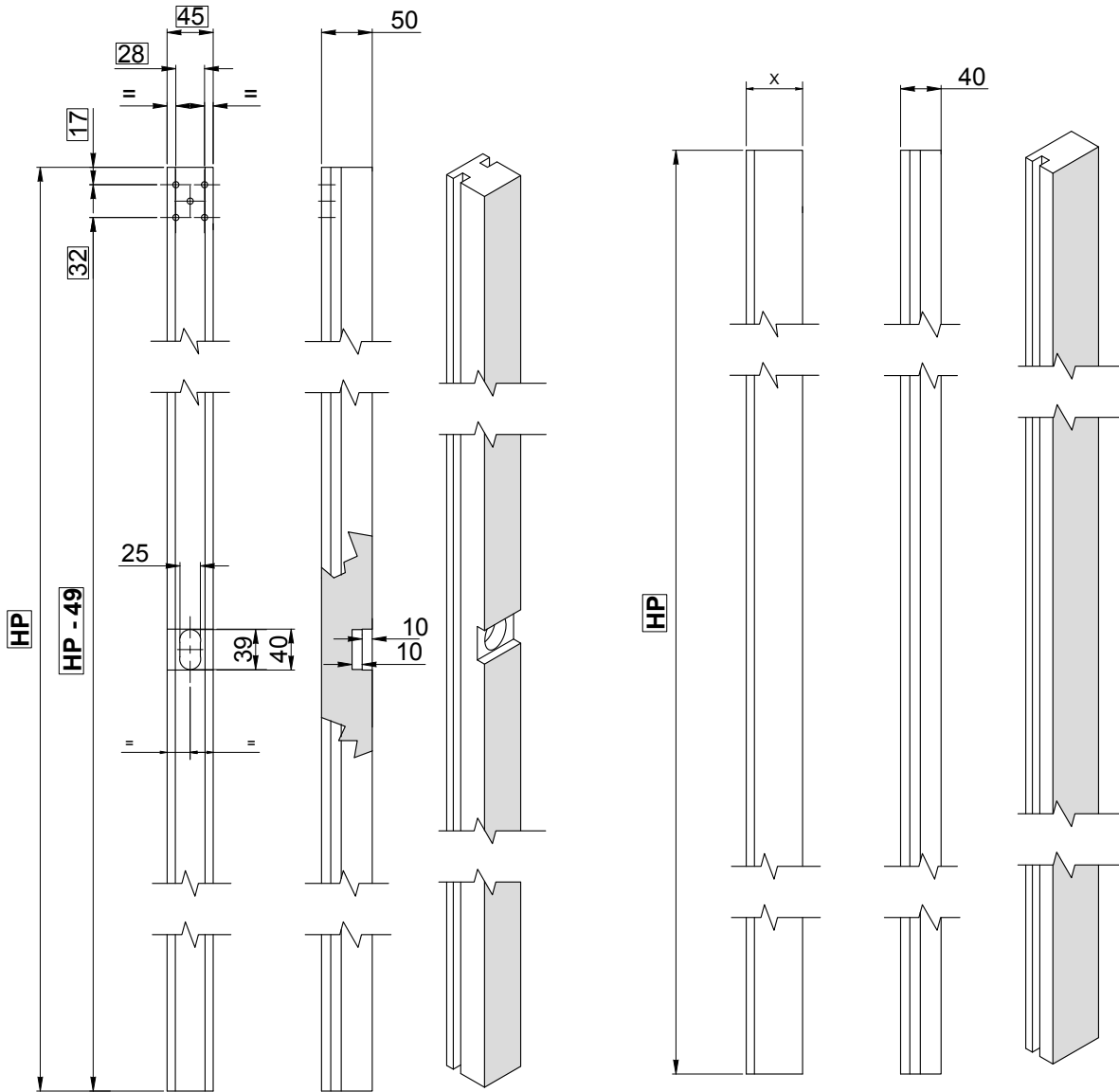

DIMENSION THAT BE ACCURATE
需精确的尺寸

X = WALL THICKNESS - 45
X=墙体厚度-45

HP = PASSAGE DIMENSION
HP=通过尺寸

--- VISIBLE SIDE
可见的边

ORIENTED DOOR偏心安装

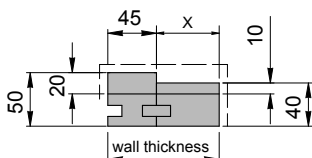

CENTERED DOOR居中安装

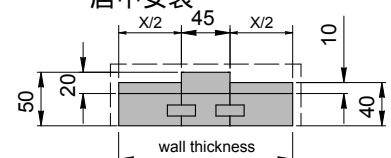

FOR CENTERED DOOR IS NECESSARY TWO SPECULAR JAMB
居中安装的门需要两个对称的套板

EXPLODED VIEW OF THE FRAME (STRAIGHT JAMB) 门套爆炸分解图 (平口门套)

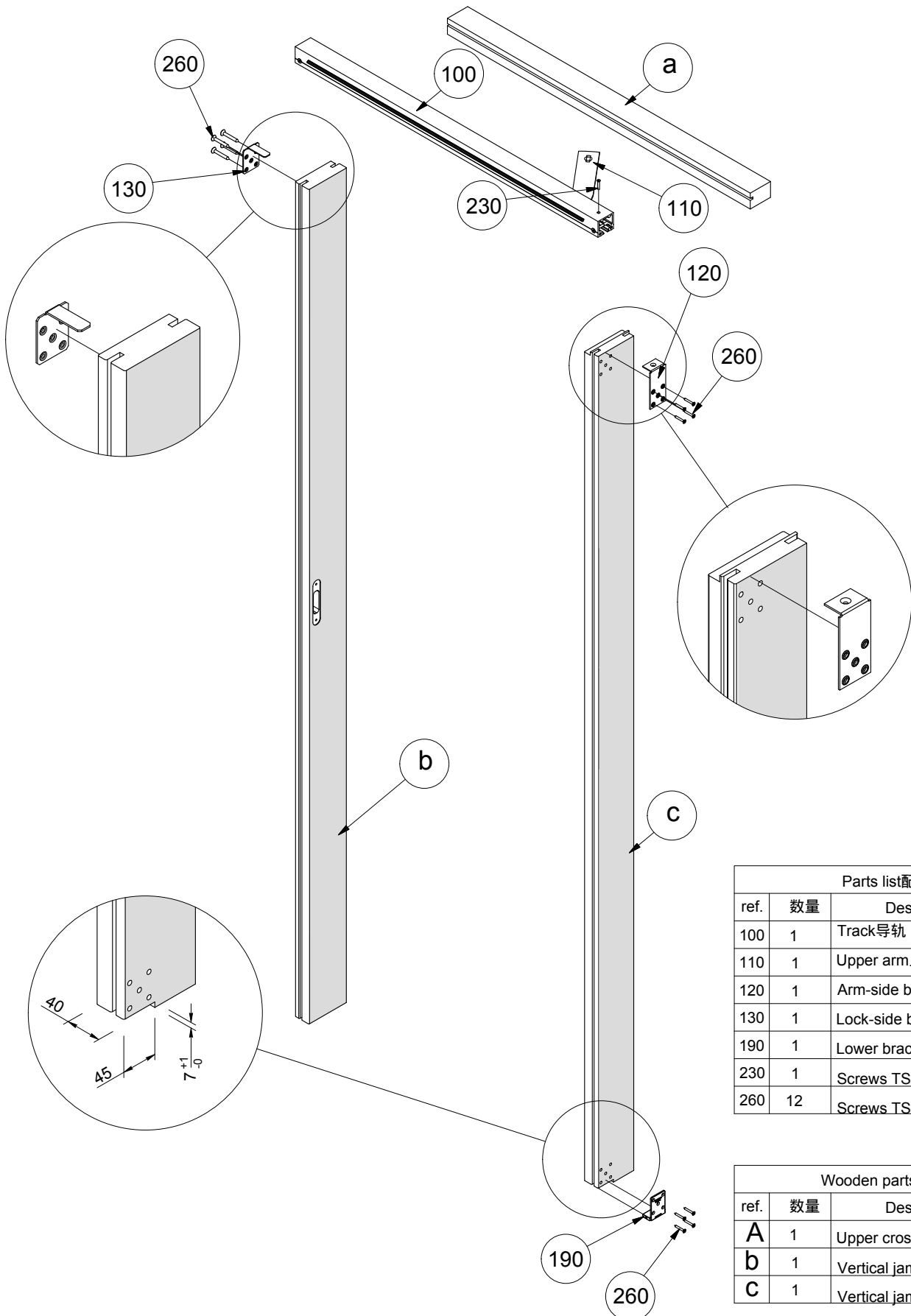

Parts list 配件清单		
ref.	数量	Description 描述
100	1	Track 导轨
110	1	Upper arm 上方支臂
120	1	Arm-side bracket 支臂侧支架
130	1	Lock-side bracket 锁侧支架
190	1	Lower bracket 下方支架
230	1	Screws TSPei M5x12 螺丝
260	12	Screws TSPcr Ø3,5x30 螺丝

Wooden parts 木线条部分		
ref.	数量	Description 描述
A	1	Upper crossbeam 上方横梁
b	1	Vertical jamb, lock side 锁侧套板
c	1	Vertical jamb, arm side 支臂侧套板

DETAILS FOR VERTICAL FRAME (STRAIGHT JAMB)垂直门套加工图 (平口门套)

ARM SIDE

LOCK SIDE

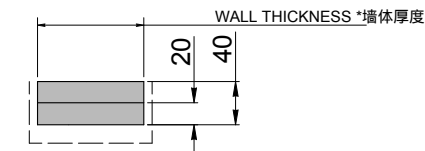
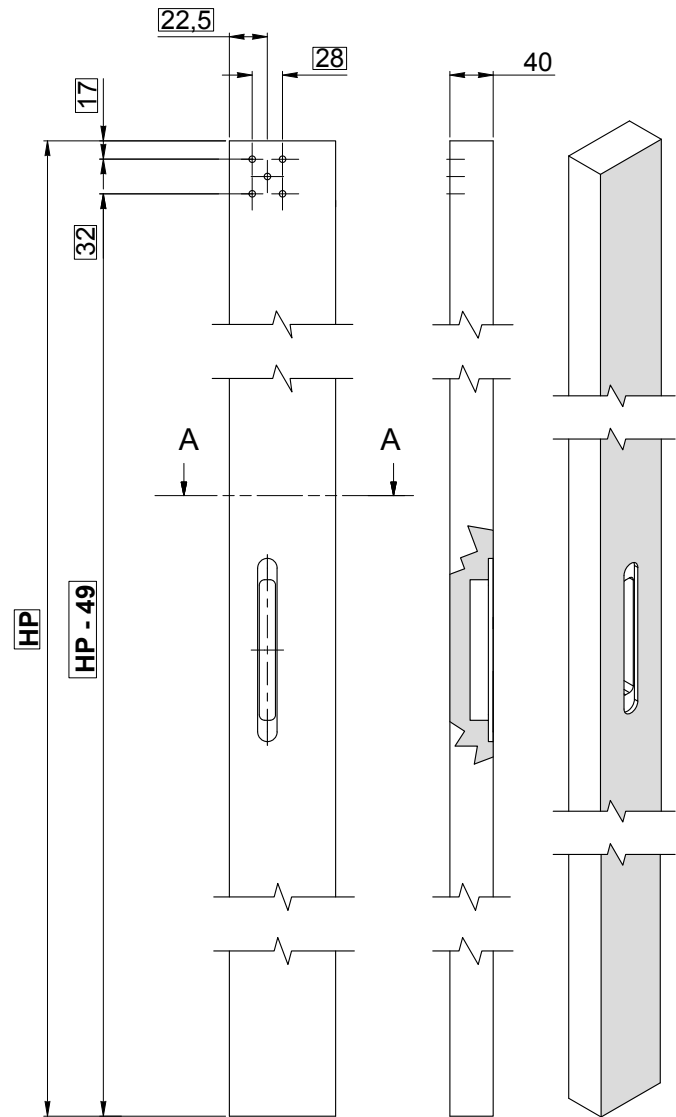
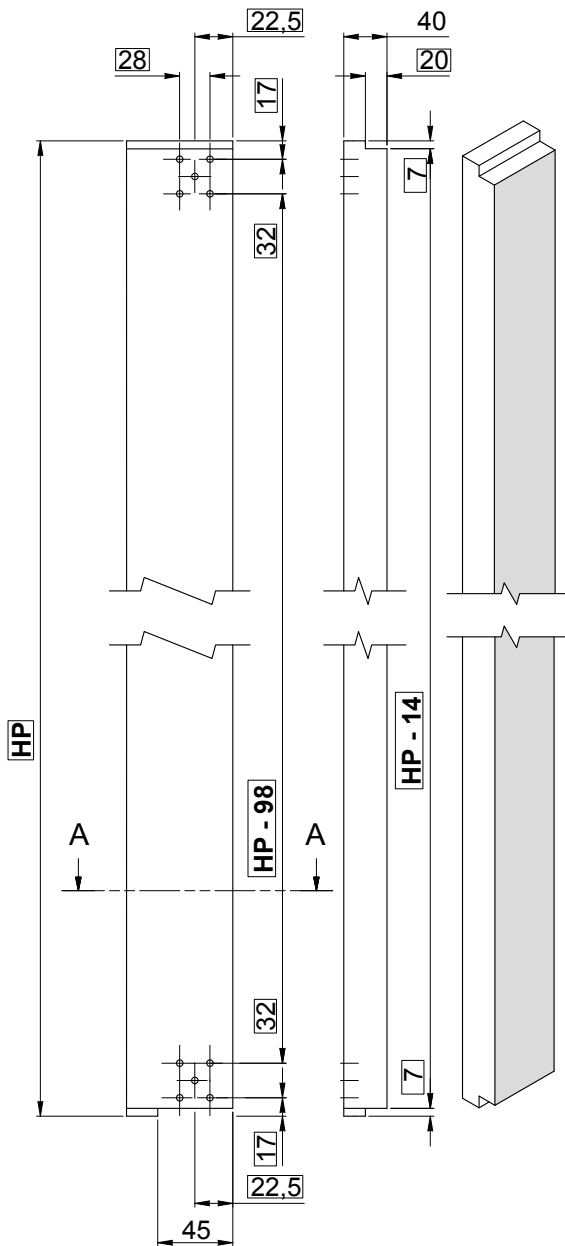

SEZ. A-A

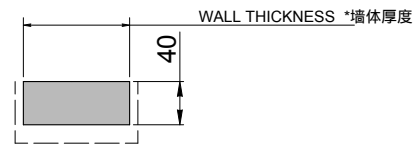

SEZ. A-A

IMPORTANT DIMENSIONS THAT MUST BE ACCURATE
重要尺寸必须精确

--- **VISIBLE SIDE**
可见的边

HP = PASSAGE DIMENSION
HP=通过尺寸

ORIENTED DOOR靠边安装

Wall Thickness *墙体厚度

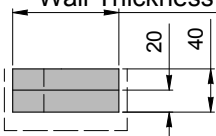

CENTERED DOOR居中安装

Wall Thickness *墙体厚度



DETAILS FOR UPPER CROSSBEAM 横向门套加工图

VALID FOR FRAME WITH DOORPOST AND FLAT FRAME
两种框型都适用

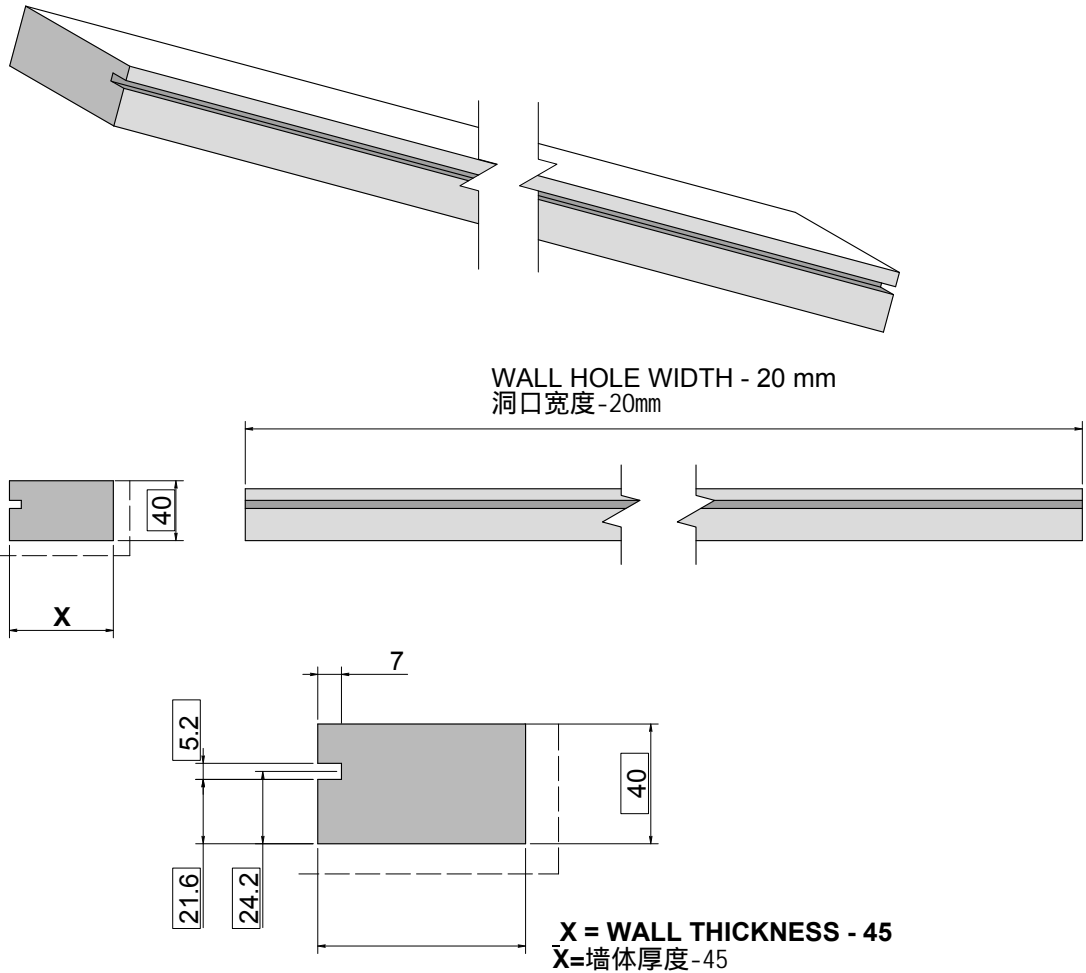

DIMENSION THAT BE ACCURATE
尺寸需精确

X = WALL THICKNESS - 45
X=墙体厚度-45

VISIBLE SIDE
可见的边

ORIENTED DOOR 靠边安装

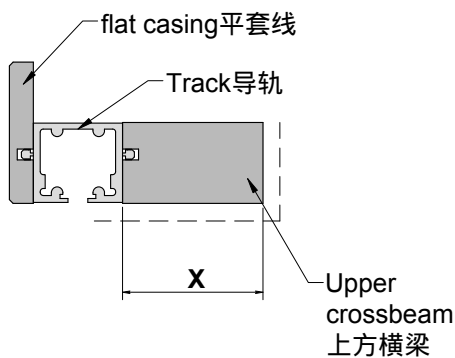

CENTERED DOOR 居中安装

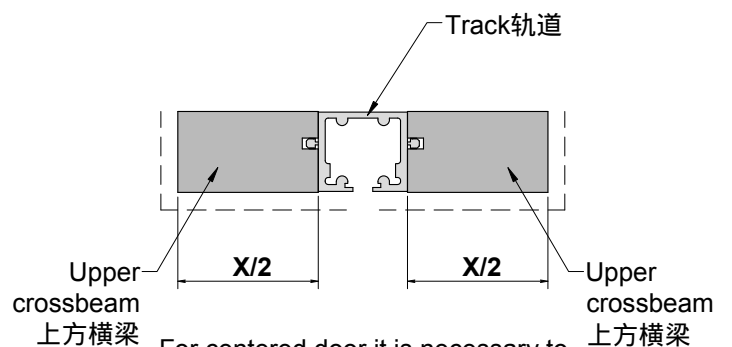

For centered door it is necessary to have two specular crossbeam.
居中安装需要两个对称的上方横梁

TRACK ADJUSTMENT TO THE WIDTH NOT STANDARD 非标宽度的轨道裁切方法

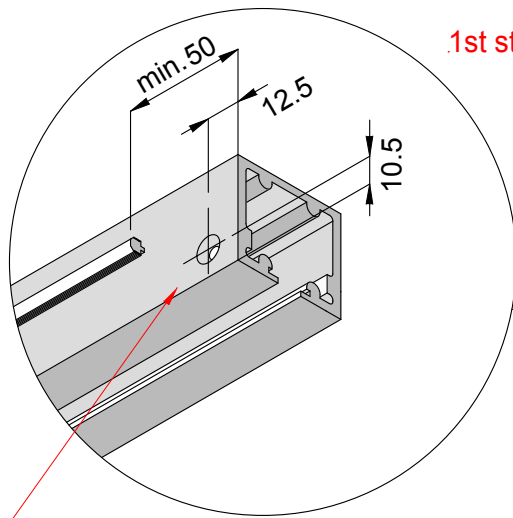

1st step - Cut the track on the mentioned side
第一步：在下方一侧切割轨道

2nd step - Drill the hole Ø 5 on both sides for M5 TSPei screw and shorten the small wings
第二步：在轨道两侧钻5mm直径沉孔，用于M5内六角螺丝并且缩短突出的小线条

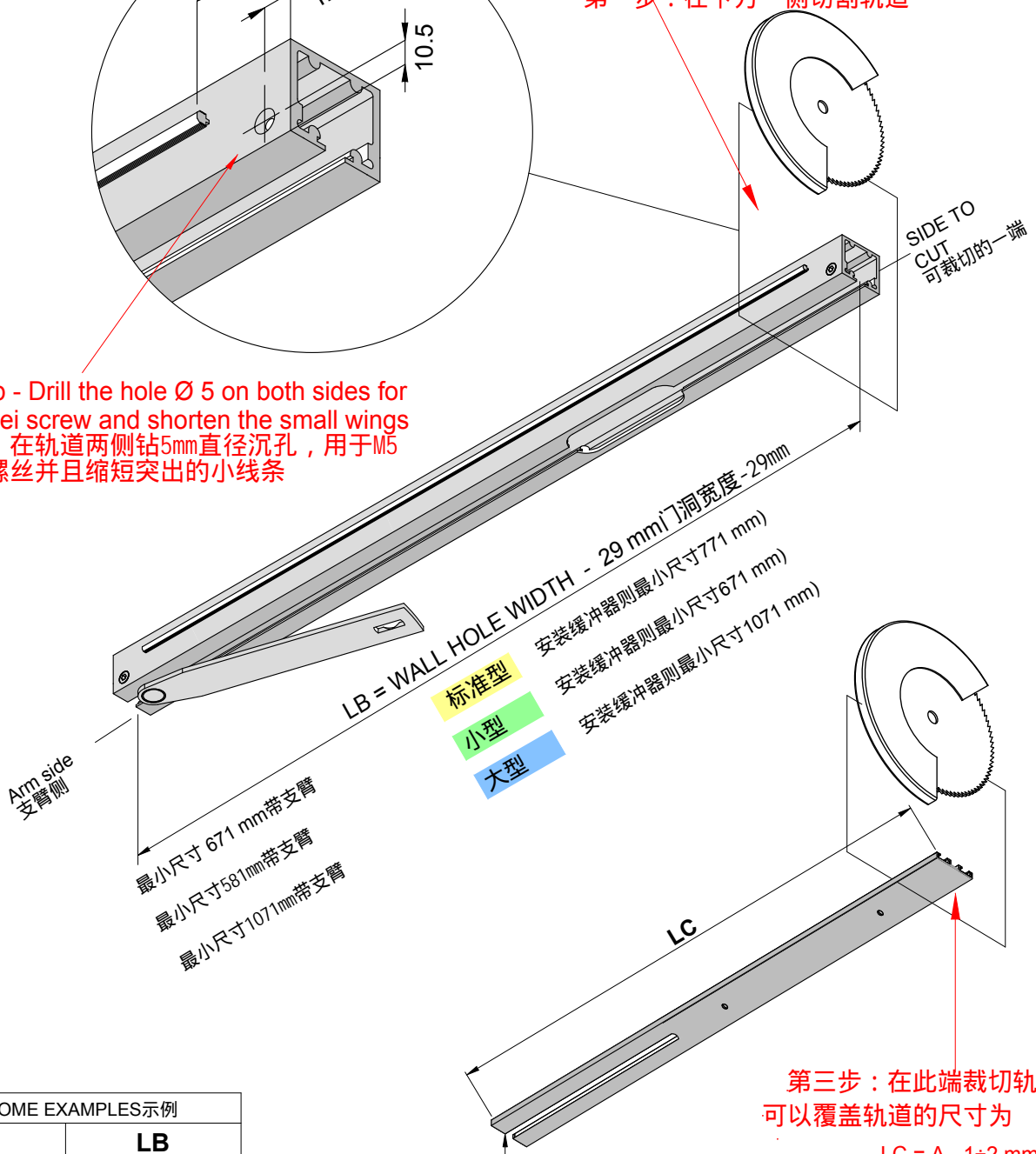

- 标准型 安装缓冲器则最小尺寸771 mm)
- 小型 安装缓冲器则最小尺寸671 mm)
- 大型 安装缓冲器则最小尺寸1071 mm)

- 最小尺寸 671 mm带支臂
- 最小尺寸 581 mm带支臂
- 最小尺寸 1071 mm带支臂

第三步：在此端裁切轨道装饰盖
可以覆盖轨道的尺寸为

$$LC = A - 1 + 2 \text{ mm}$$

track cover caps
导轨装饰盖

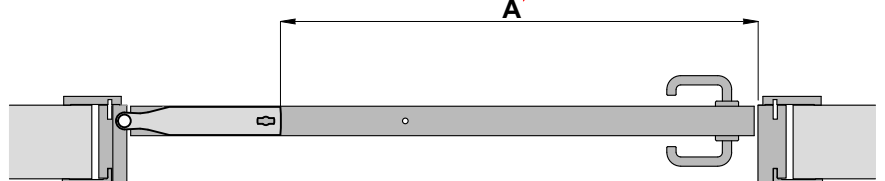

SOME EXAMPLES 示例	
LFM 墙洞宽度	LB 轨道长度
700	671
725	696
750	721
775	746
825	796
875	846
925	896
975	946
LB = LFM - 29	

ROD KIT SHORTNABLE 垂直连接杆的裁切

ADJUSTMENT OF THE CONNECTING ROD FOR NOT STANDARD HEIGHTS
非标高度时，可调节连接杆的长度

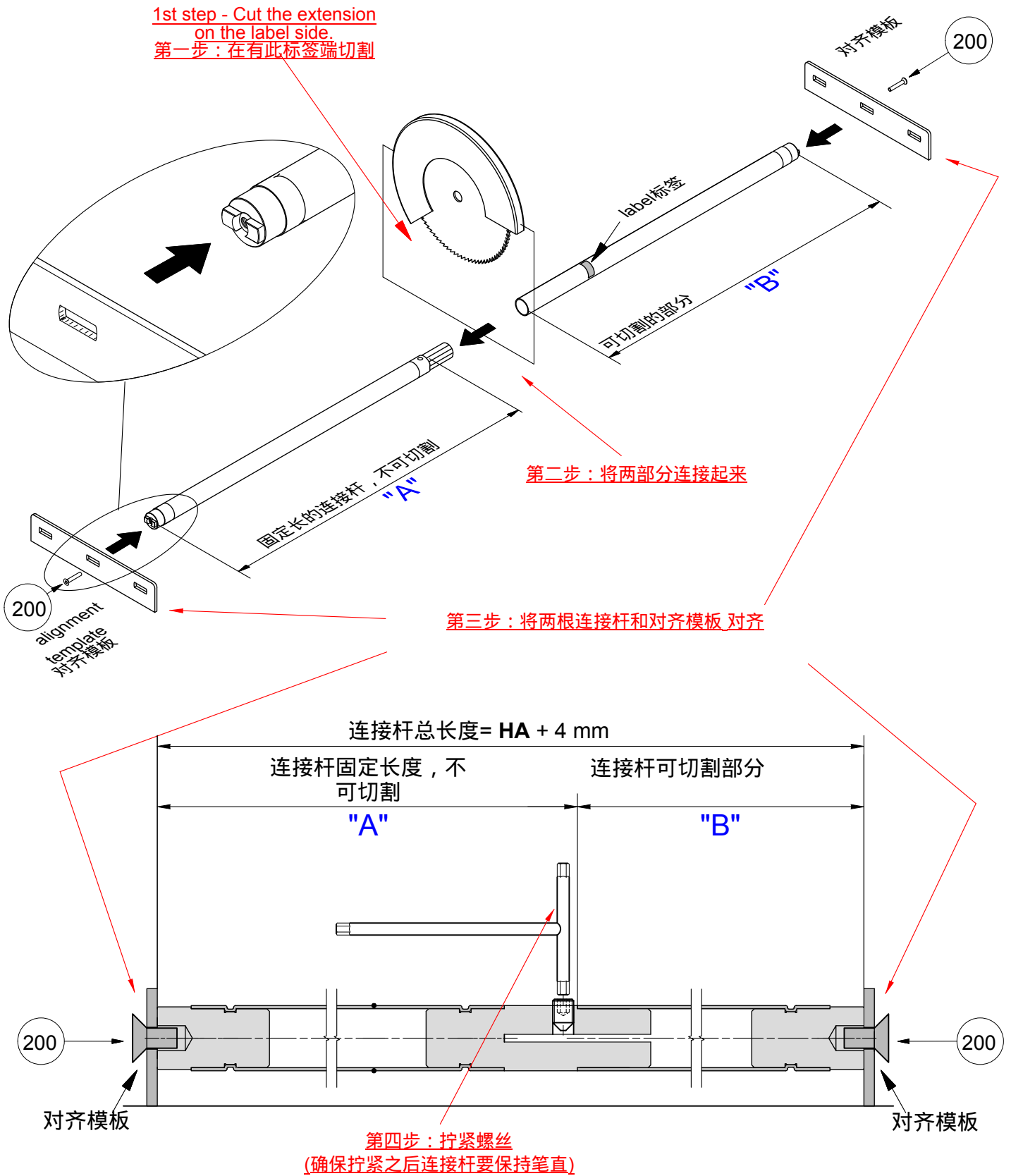

连接杆型号	最大HP	尺寸 "A" 固定尺寸	尺寸 "B" 可裁切	
555250CP	2500	1258,5	HA - 1254,5	现货
555300CP	3000	1508,5	HA - 1504,5	提前订货

KIT UNION TRACKS FOR DOOR WITH TWO DOOR LEAVES ERGON LIVING SYSTEM
双扇门的轨道工具套件

1

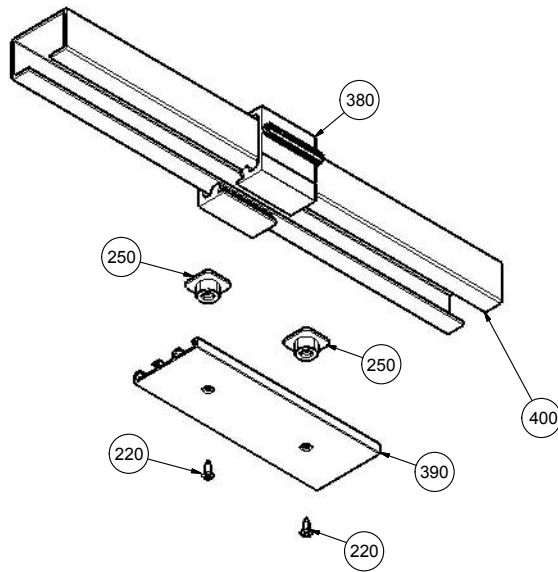

型号 564000

Part list配件清单		
ref.	qty	Description描述
220	1	Screw TSPcr Ø3X10自攻螺丝
250	2	轨道装饰盖安装堵头
380	1	Track extension轨道延长部分
390	1	Track cover extension轨道装饰盖延长
400	1	Track graft junction轨道连接接头

2

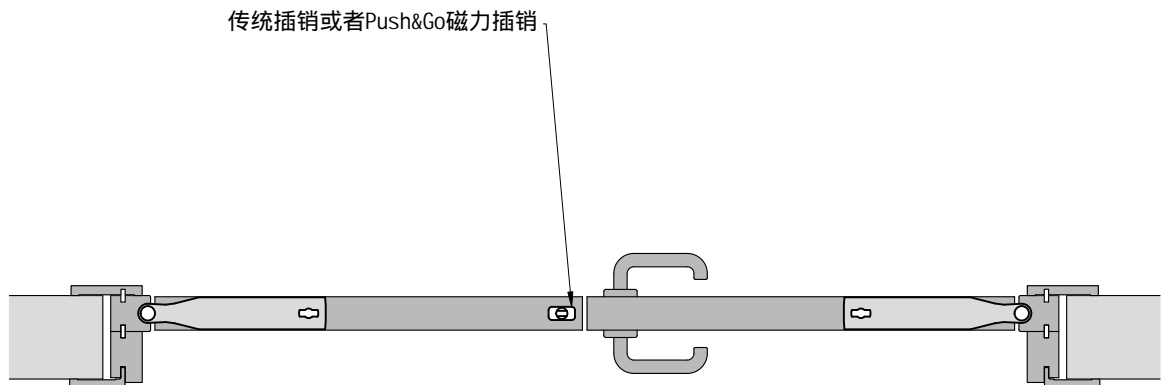

N.B.: 墙体厚度的限制参考第10页的说明

LFM 最小门洞宽度 1600 mm. 标准型支臂, 安装缓冲器, 则**LFM** 最小门洞宽度 1700 mm.

LFM 最小门洞宽度1400 mm. 小型支臂, 安装缓冲器, 则 **LFM** 最小门洞宽度1500 mm.

LFM 最小门洞宽度2300 mm. 大型支臂, 安装缓冲器, 则**LFM** 最小门洞宽度 2300 mm.

For dimensions smaller than those indicated, contact Celegon S.r.l.

KIT UNION TRACKS FOR DOOR WITH TWO DOOR LEAVES ERGON LIVING SYSTEM

3

双扇门的轨道工具套件

Arm side

Choice of the tracks use

The sum of the track chosen must be the same or higher than the **Width Wall Hole**

- ex. : **LFM 2000** n.º 2 tracks **LFM 1000** (already on measure)
- LFM 1960** n.º 2 tracks **LFM 1000** (to be cut)
- LFM 2060** n.º 2 tracks **LFM 1050** (to be cut)

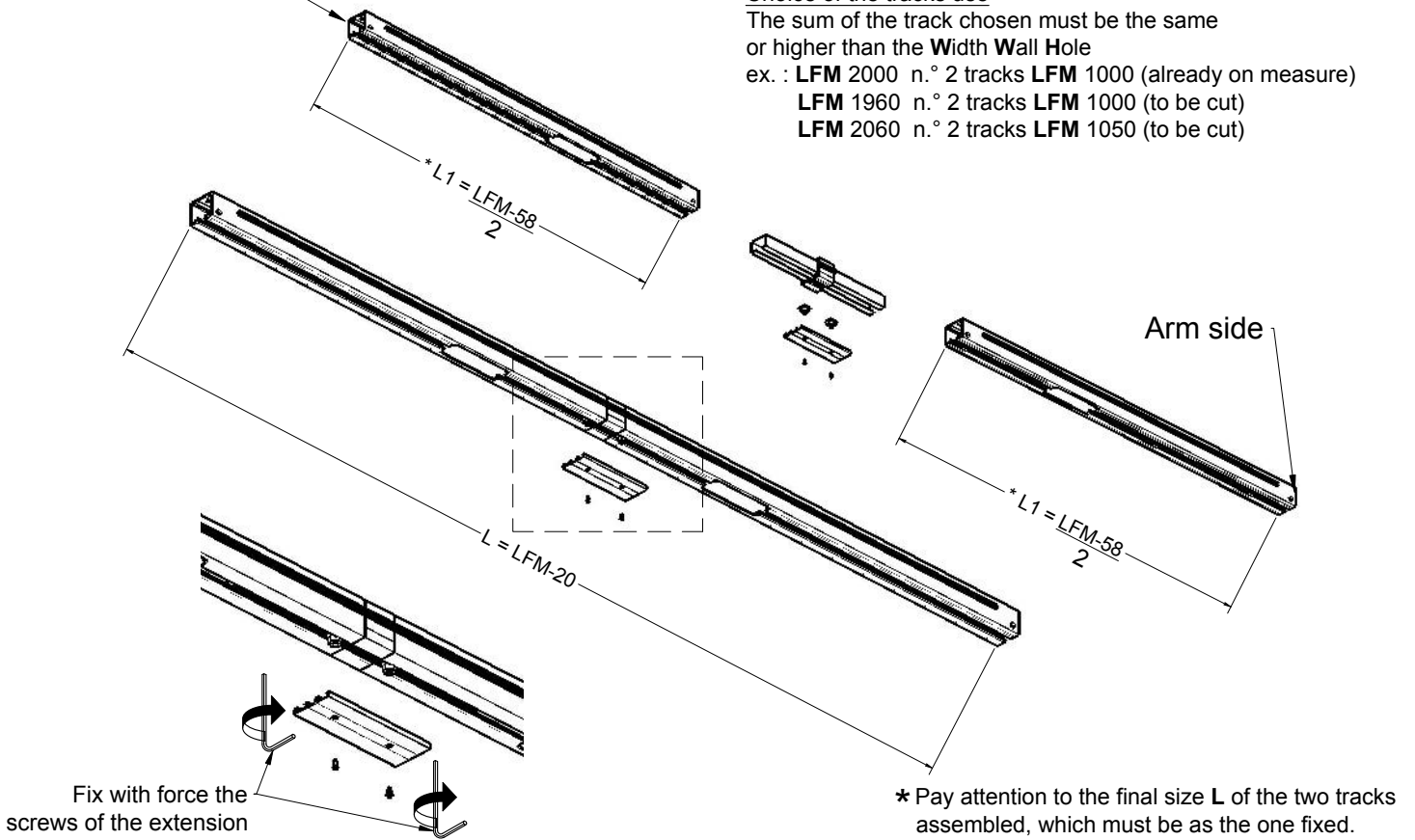

Fix properly the track to the upper wall through the hole you see on the track extension (380) Before installing the doors be sure that internal track are clean.

4

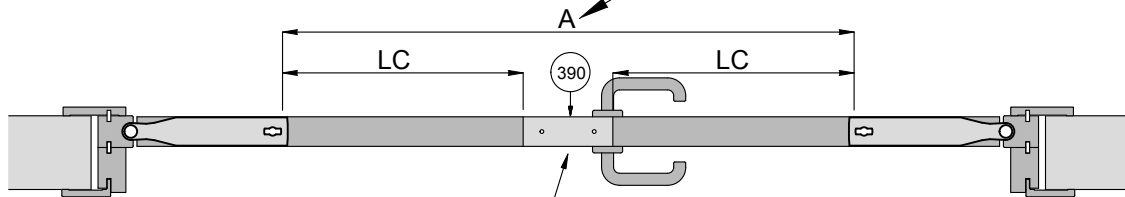
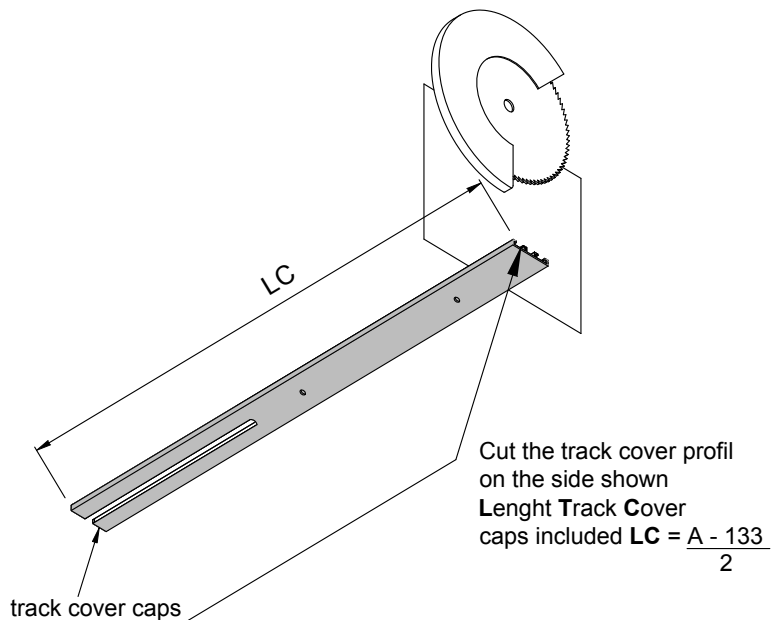
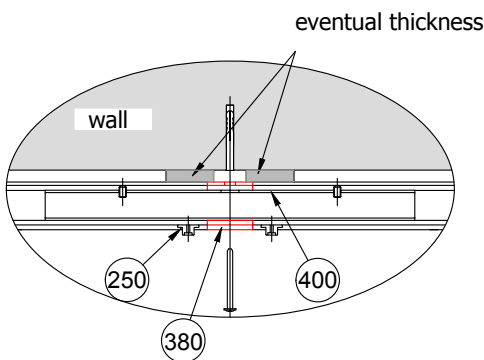

Create the opening to block the secondary door leaf for the traditional latch,
OR

For the Push&Go EVO system use the dedicated kit, see next page.

MAGNETIC STRIKER PLATE FOR "Push&Go EVO" 磁力插销扣板的安装板

For use with double door leaves with Ergon Living system.

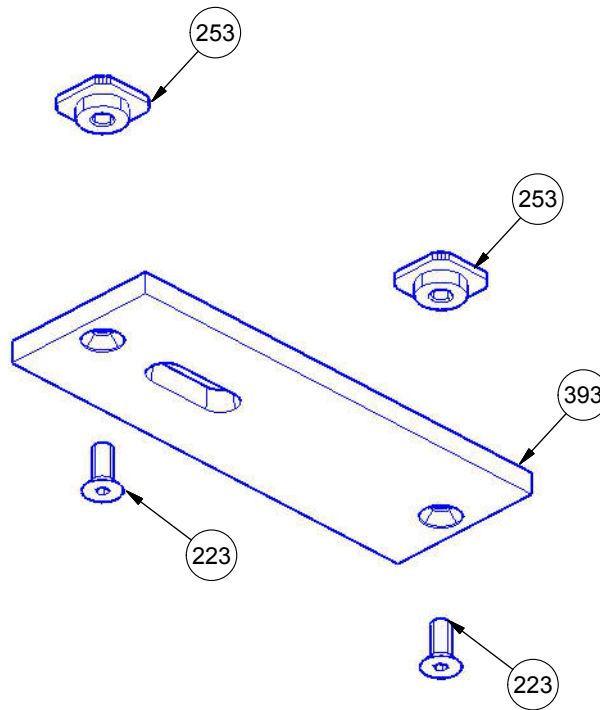

Silver item number 4150IA
Black item number 4150IN

ref.	qty	Parts list
223	1	Screw TSPEI M5x12
253	1	Plate fixing insert
393	1	Magnetic striker plate

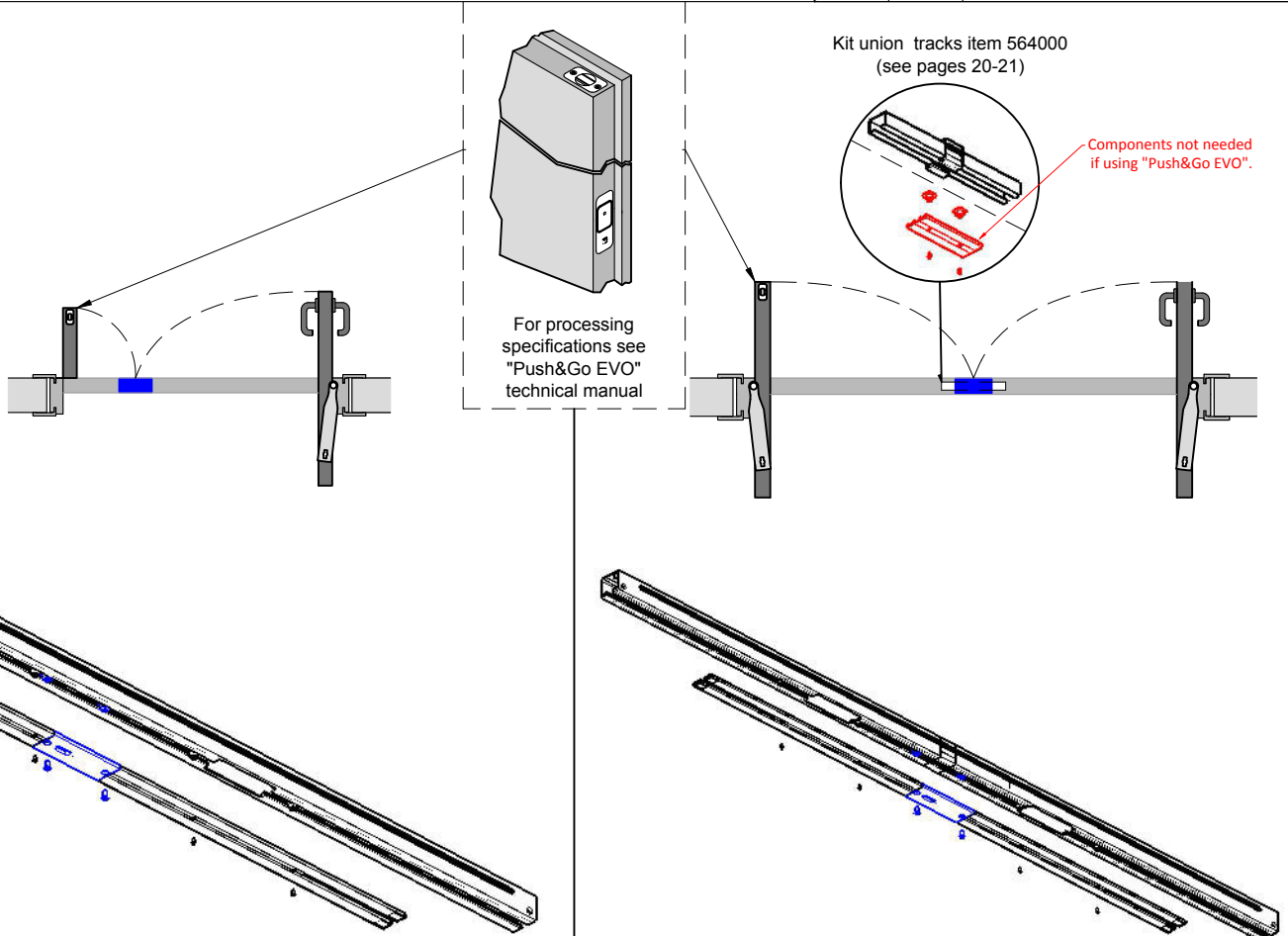

ASSEMBLING THE HARDWARE IN THE DOOR LEAF 门扇五金的组装

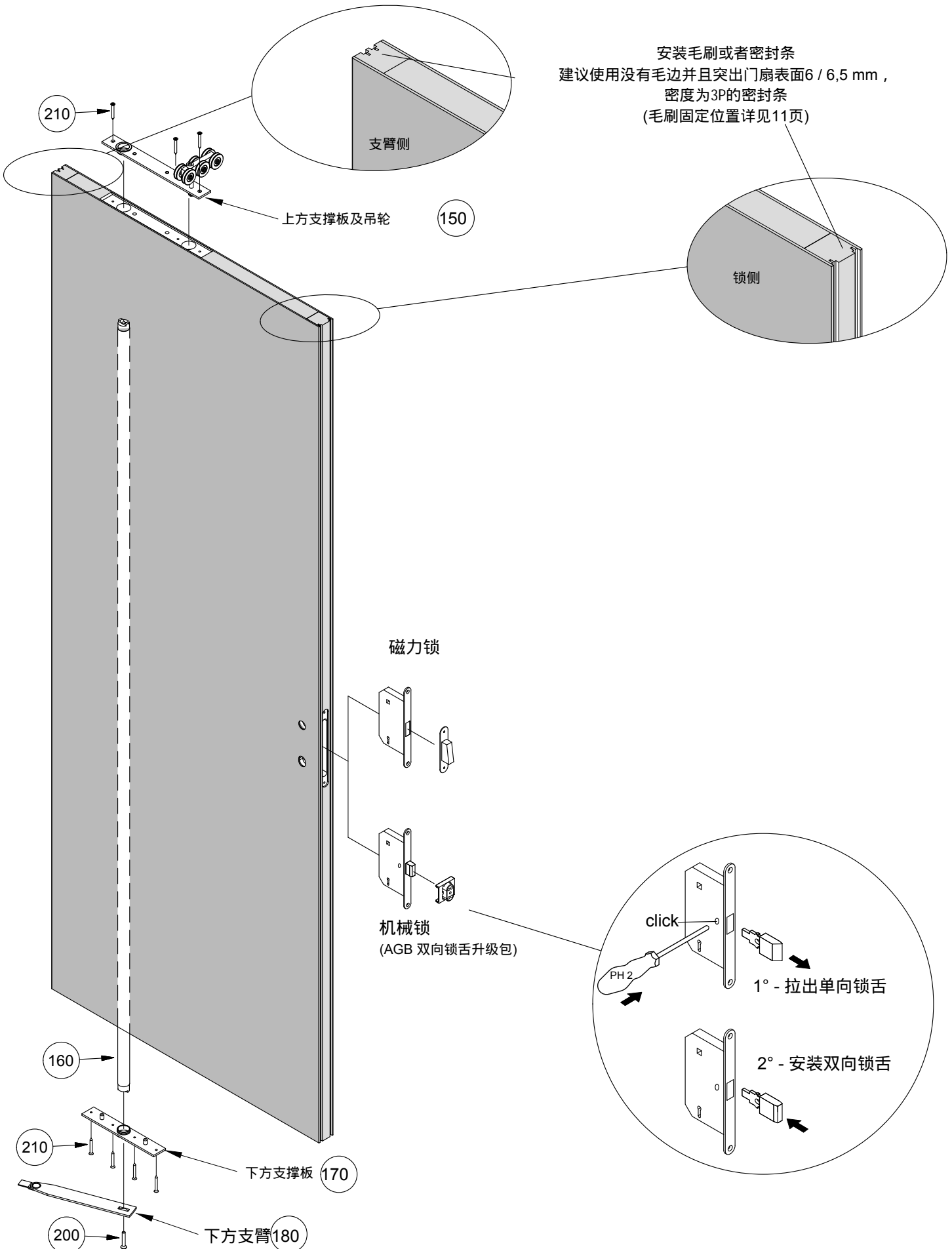

ASSEMBLY FRAME AND TRACK 轨道与门套的组装

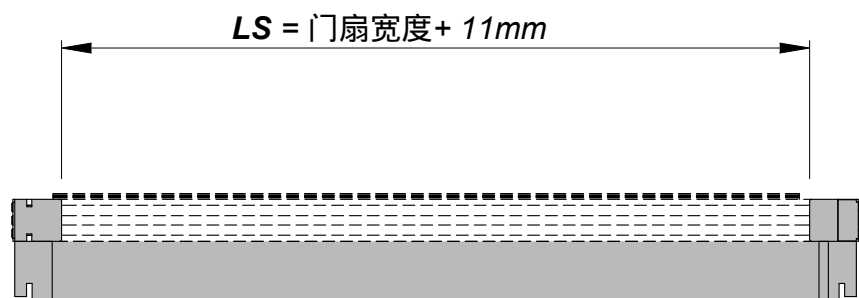
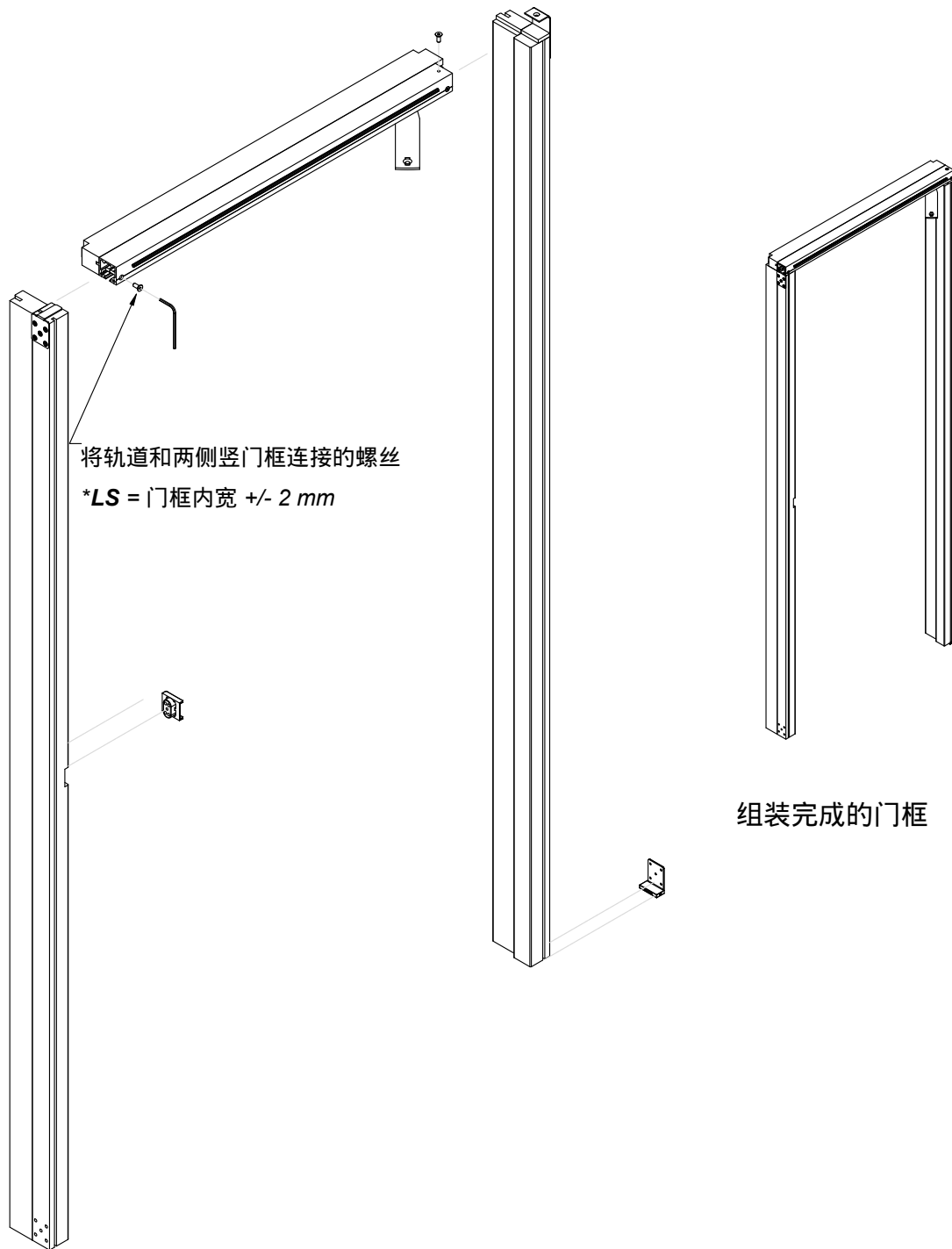

COMPLETE FRAME INSTALLATION 门套的安装

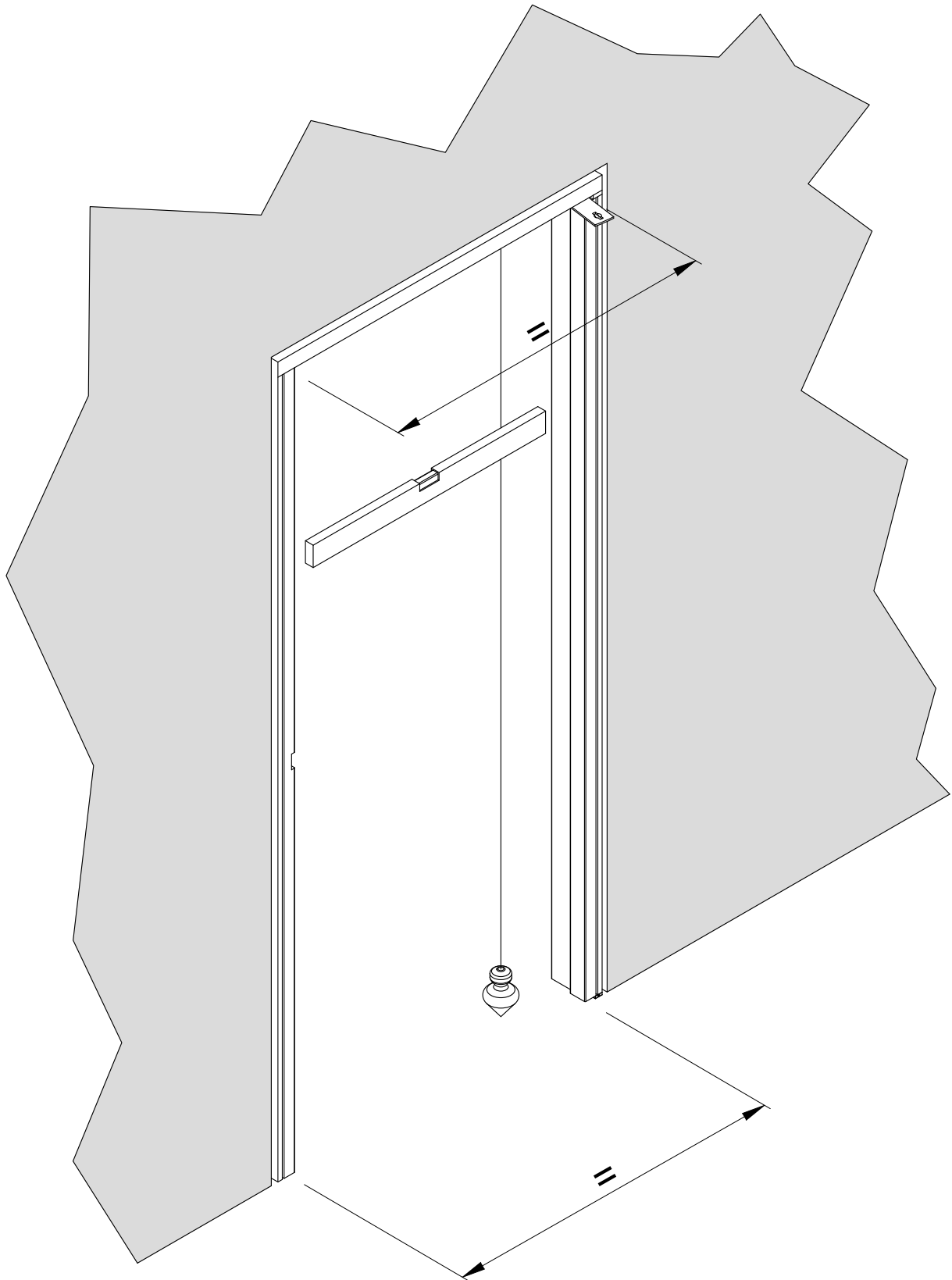

注意：导轨必须水平，竖框必须垂直

DOOR LEAF INSTALLATION 门扇的安装

USE THE BLOCKING SCREW TO INSERT THE UPPER ARM INTO THE ROD SEATING

使用此螺丝，将上方支臂插入连接杆的端头

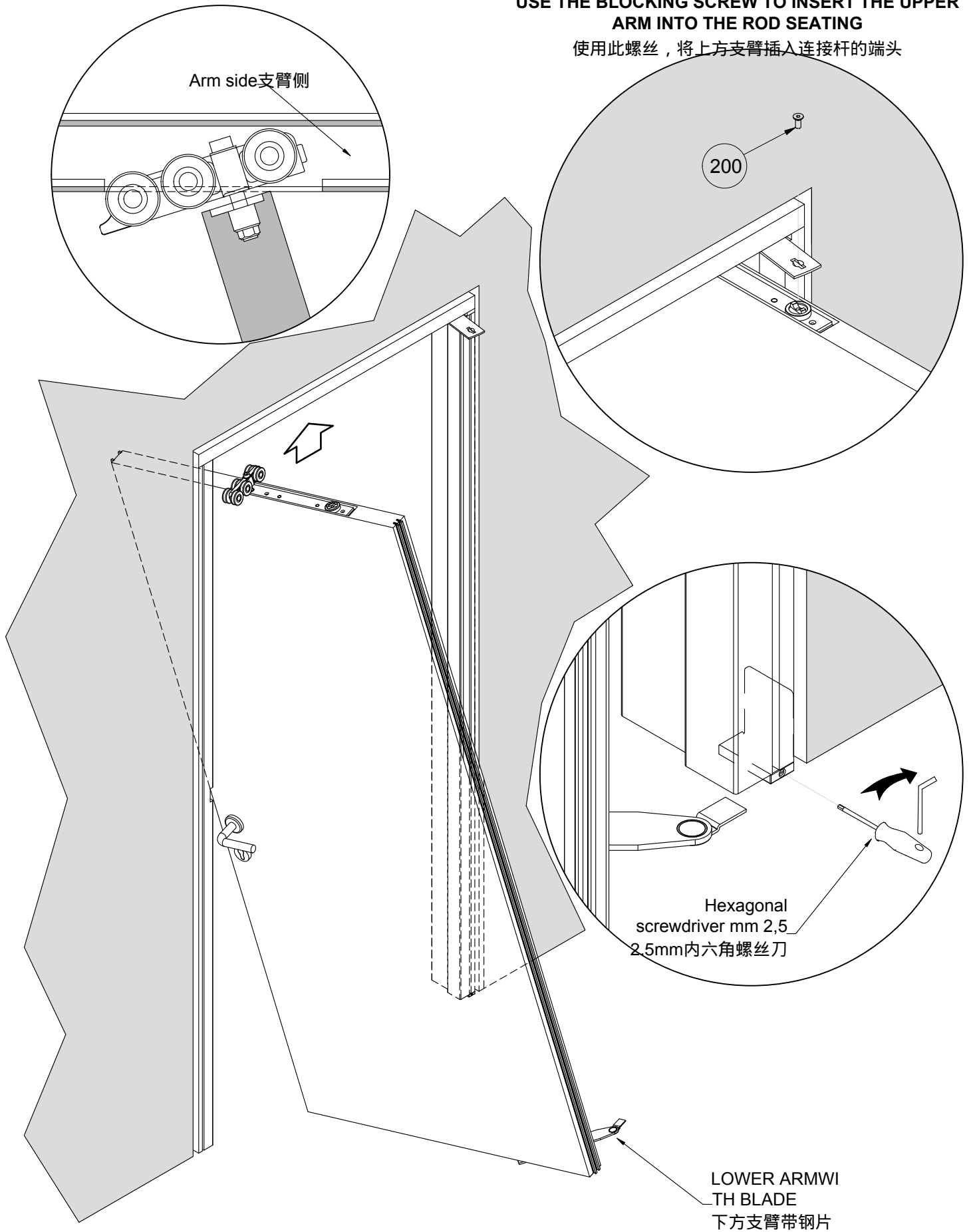

ADJUSTING DOOR LEAF AND DOOR JAMB | 门扇门套的调节

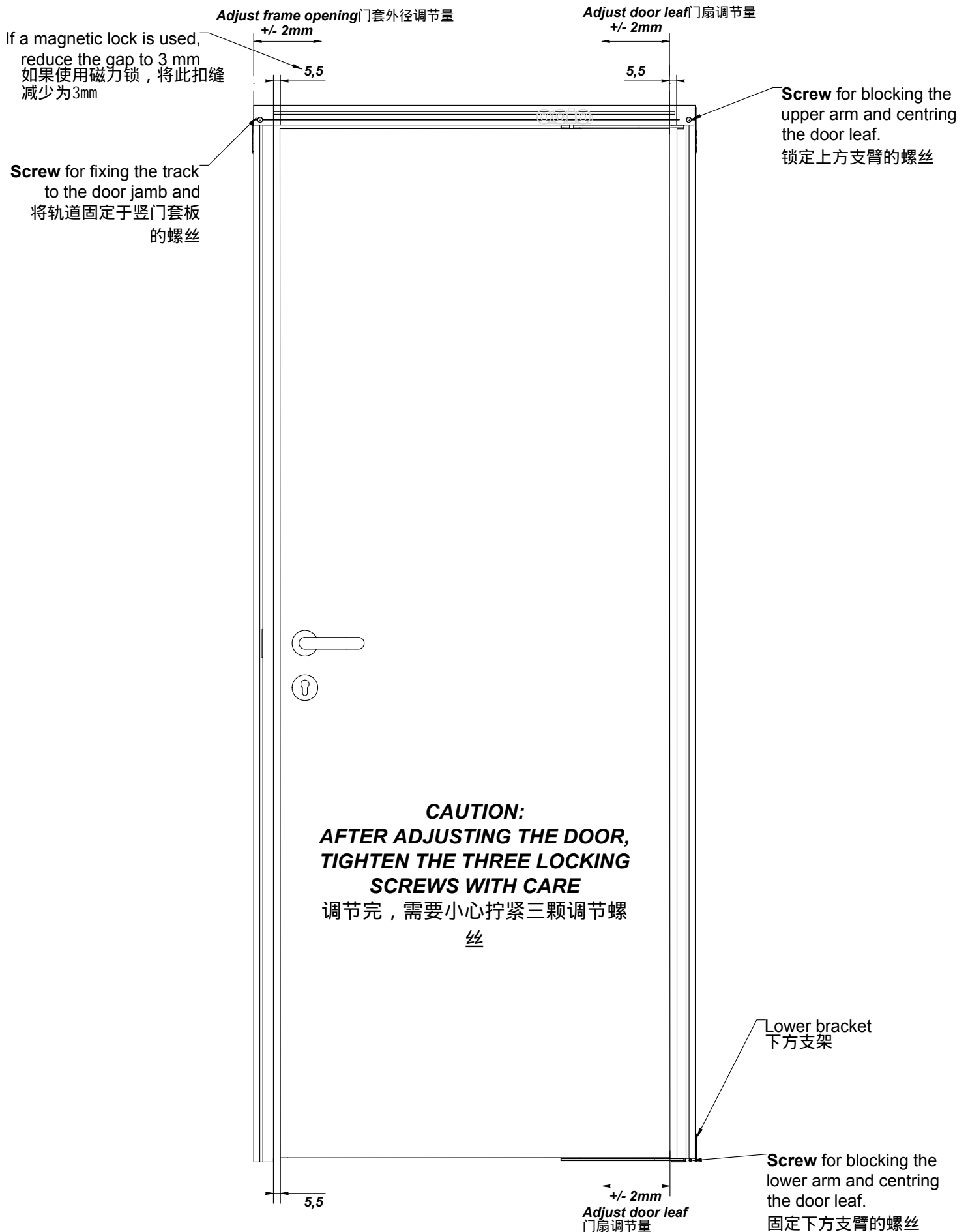

"SOFT OPENING" INSTALLATION (OPTIONAL) 缓冲器的安装 (可选)

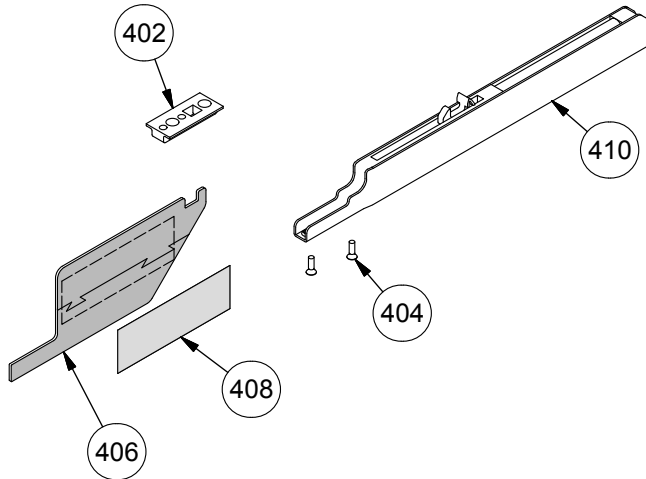

Parts list 部件清单		
ref.	qty 数量	Description 描述
402	1	Activator 缓冲触发器
404	2	Screw TSP+ M3x8 - ISO 7046 平头螺丝
406	1	Activator positioning template 触发器定位模板
408	1	Sticker 贴纸
410	1	Soft Opening 开门缓冲器

Installation 安装说明

- 1) 将门套和轨道组装好，并固定于墙上
- 2) 确保吊轮有缓冲器的连接孔

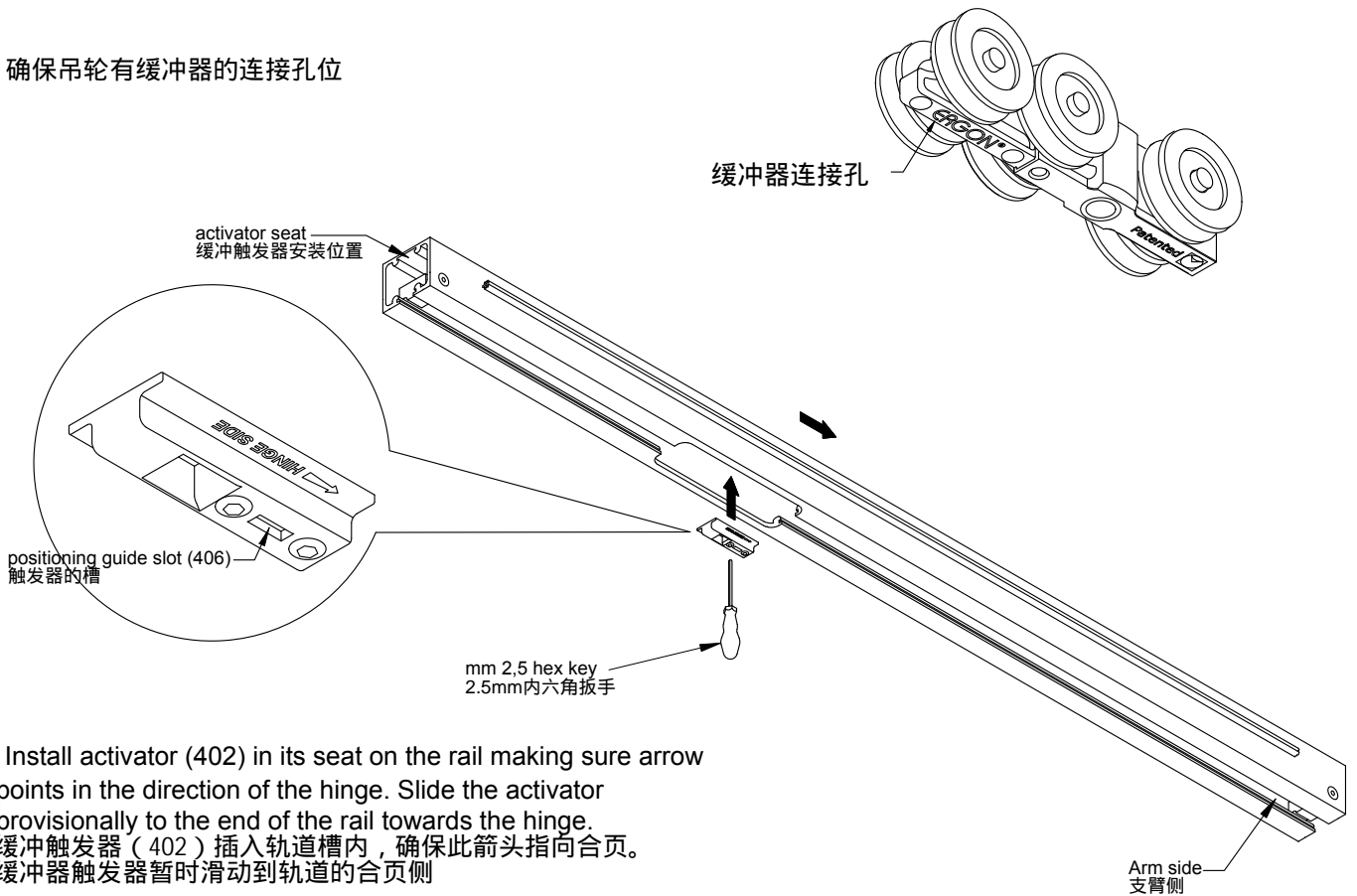

- 3) Install activator (402) in its seat on the rail making sure arrow points in the direction of the hinge. Slide the activator provisionally to the end of the rail towards the hinge.
将缓冲触发器 (402) 插入轨道槽内，确保此箭头指向合页。
将缓冲器触发器暂时滑动到轨道的合页侧
- 4) Hang the door and mount the hinge arm. Adjust the door normally and open it all the way. 将门扇悬挂并安装支臂。
调节门使其所有位置开启正常

N.B. If the door is already installed, remove the track cover and then install the activator in its seat on the rail.

注意：如果门扇已经安装完毕，需要先拆除轨道装饰盖，将缓冲触发器安装在轨道内

"SOFT OPENING" INSTALLATION (OPTIONAL) 缓冲器的安装 (可选)

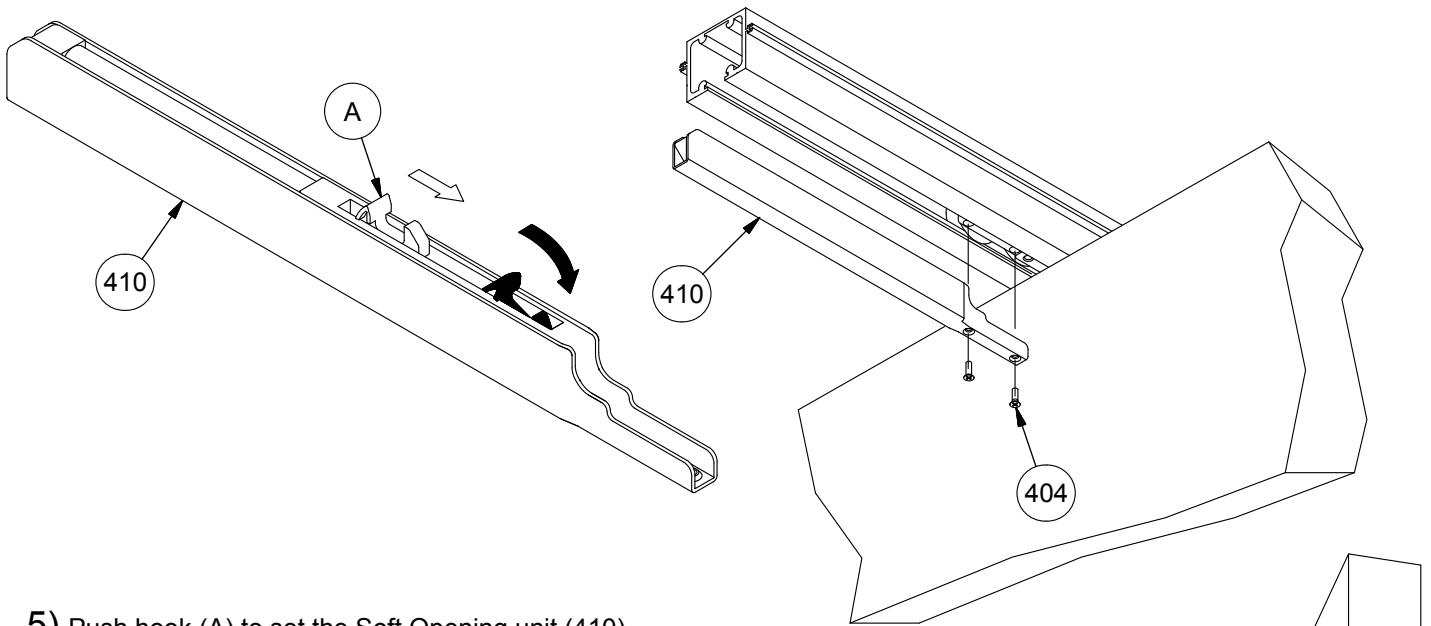

5) Push hook (A) to set the Soft Opening unit (410).

Mount Soft Opening unit to wheel unit using the screws provided (404).

推动挂钩 (A) 以启动开门缓冲器。将开门缓冲器用螺丝 (404) 安装于吊轮上。

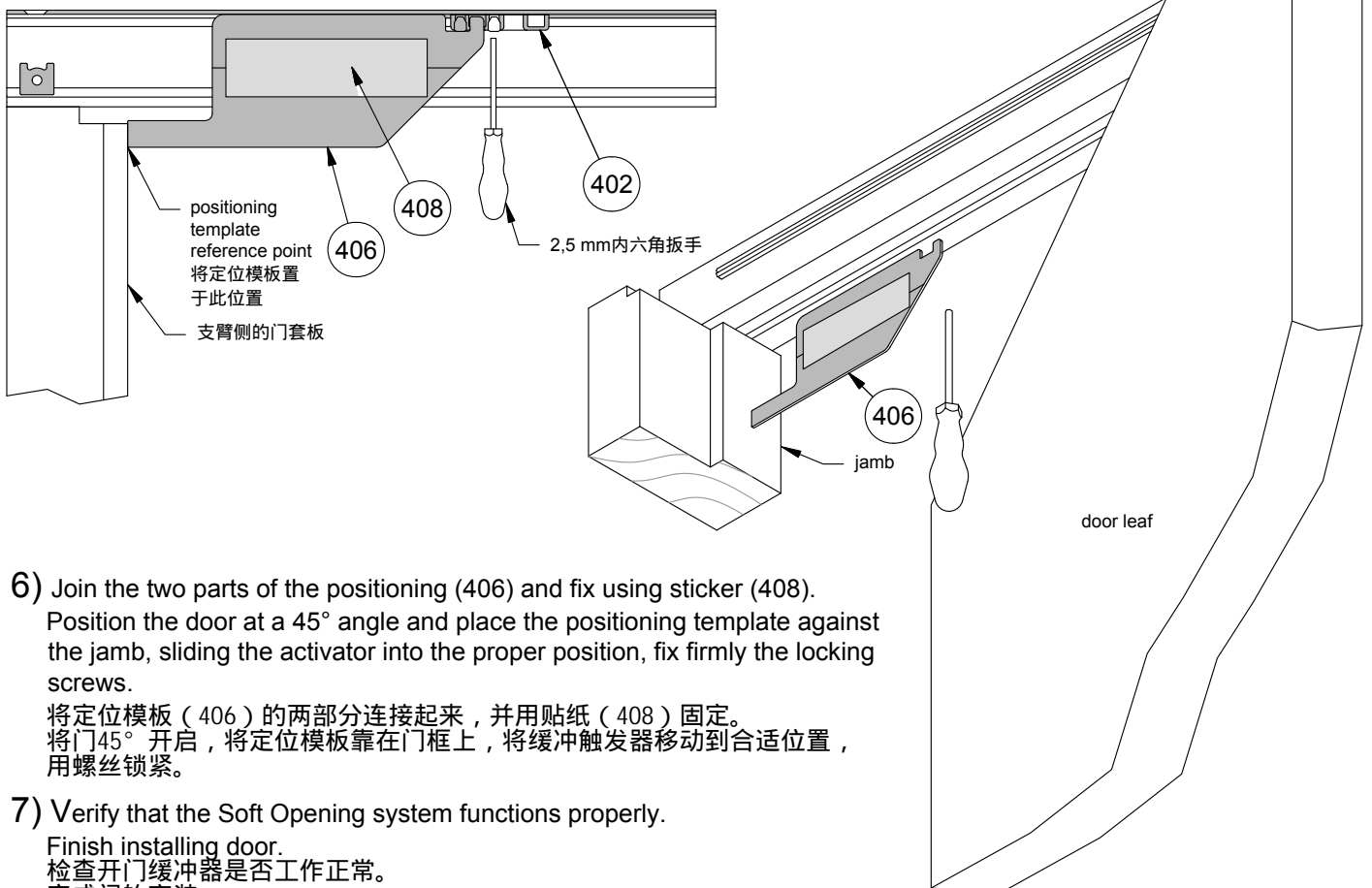

6) Join the two parts of the positioning (406) and fix using sticker (408).

Position the door at a 45° angle and place the positioning template against the jamb, sliding the activator into the proper position, fix firmly the locking screws.

将定位模板 (406) 的两部分连接起来, 并用贴纸 (408) 固定。
将门45° 开启, 将定位模板靠在门框上, 将缓冲触发器移动到合适位置, 用螺丝锁紧。

7) Verify that the Soft Opening system functions properly.

Finish installing door.
检查开门缓冲器是否工作正常。
完成门的安装。

FRAMES AND TRACK COVER INSTALLATION 门套和轨道装饰盖的安装

如果门框有启口 (参见下图), 轨道装饰盖需要在下图圈出的一段多裁切20mm
TRACK COVER MUST BE SHORTENED BY 20 mm ON THE SIDE MARKED WITH THE CIRCLE.

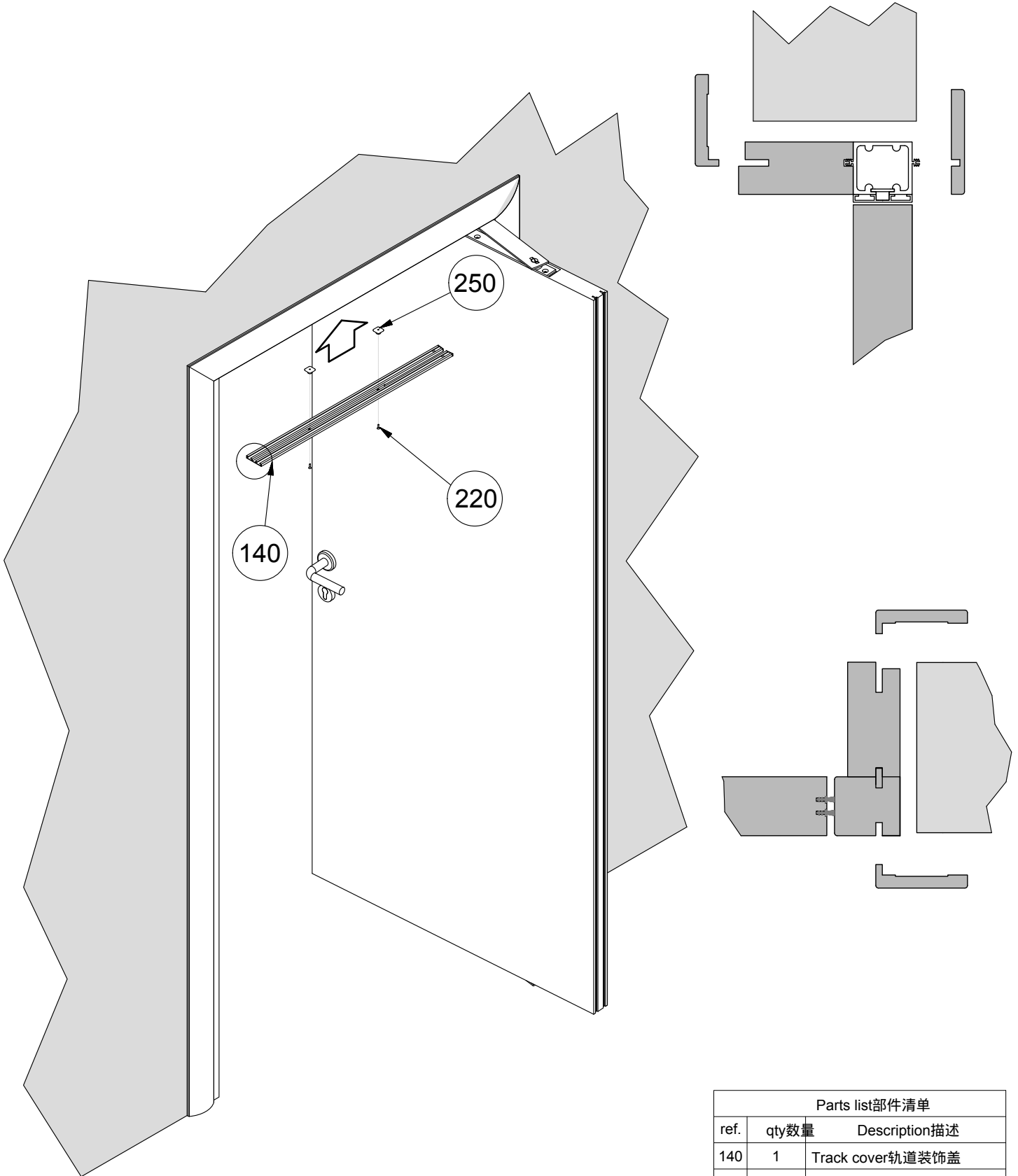

Parts list 部件清单		
ref.	qty 数量	Description 描述
140	1	Track cover 轨道装饰盖
220	2	Screw TSPcr Ø3x10 自攻螺丝
250	2	Insert for cover track fixing 轨道装饰盖安装堵头